

ENGINE CONTROL (5S-FE w/ ECT)

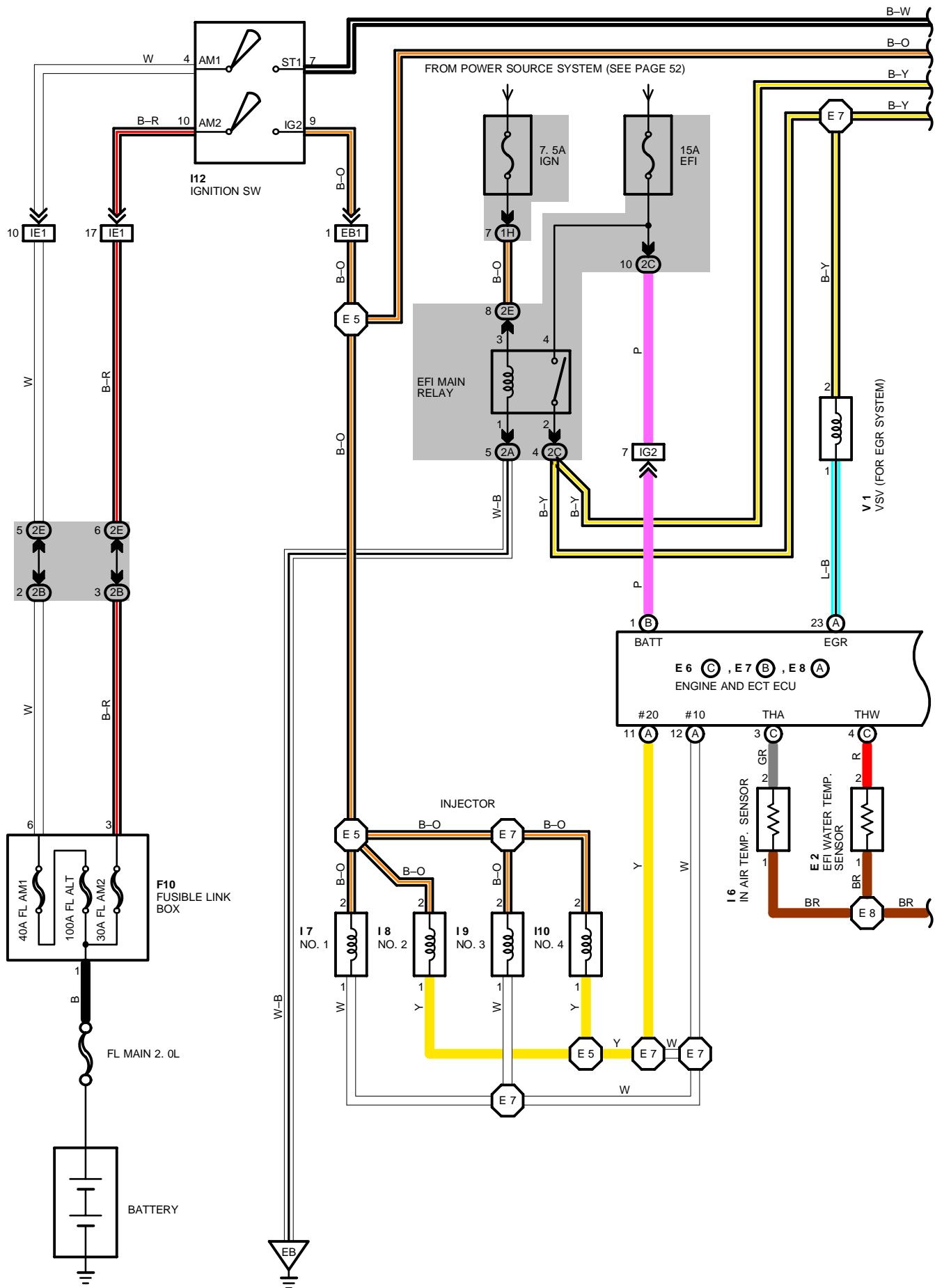

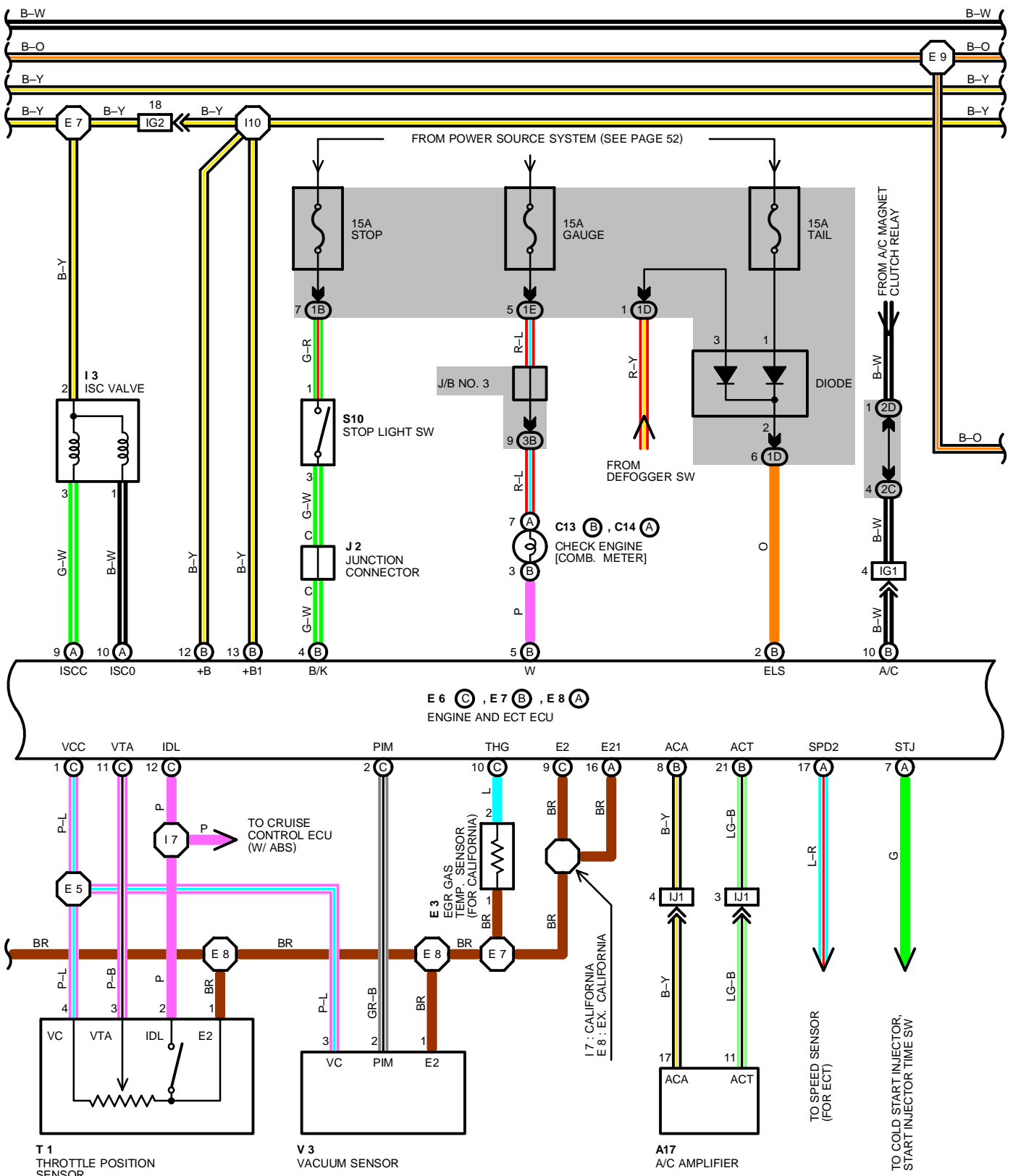

ENGINE CONTROL (5S-FE w/ ECT)

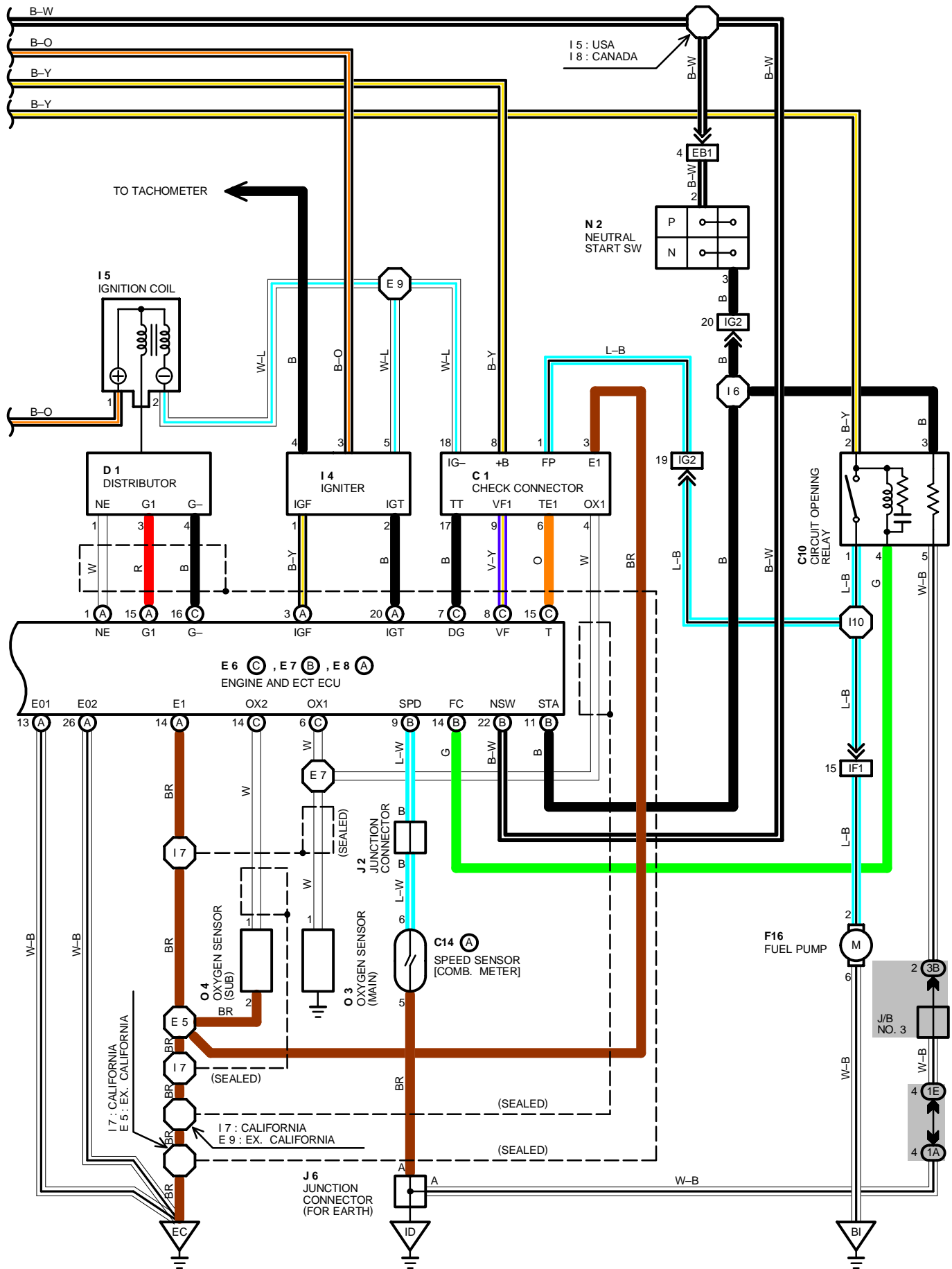

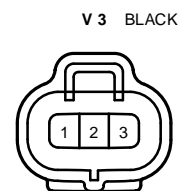
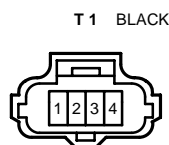
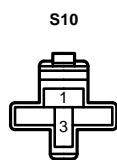
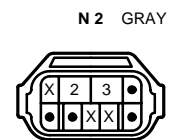
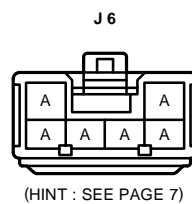
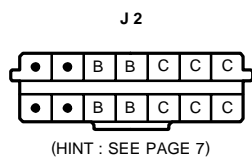
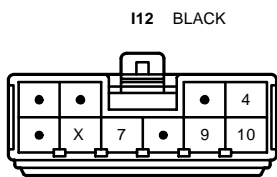
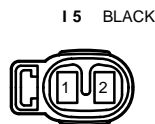
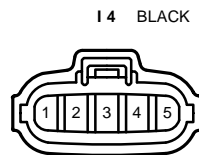
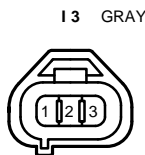
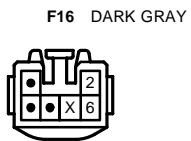
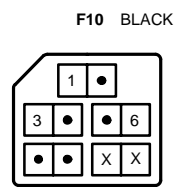
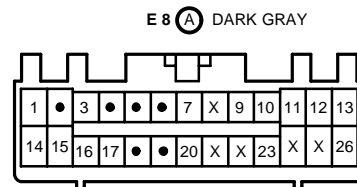
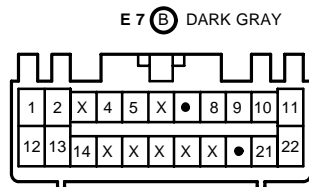
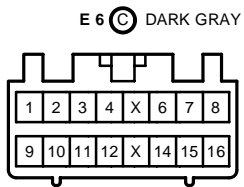
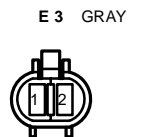
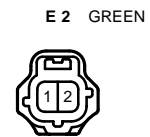
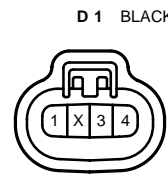
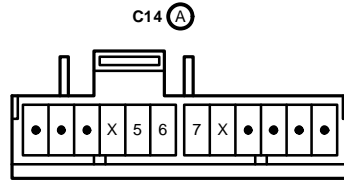
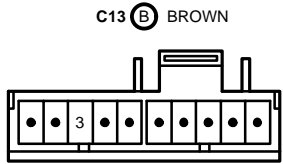
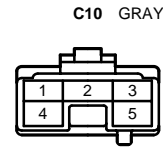
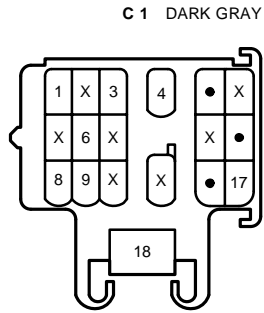
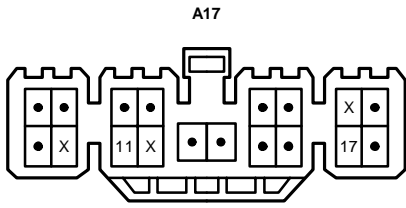

ENGINE CONTROL (5S-FE w/ ECT)

SERVICE HINTS

E 6, E7, E8 ENGINE ECU

VOLTAGE AT ECU WIRING CONNECTORS

BATT-E1	: ALWAYS 10.0-14.0 VOLTS
+B-E1	: 10-14.0 VOLTS (IGNITION SW AT ON POSITION)
+B1-E1	: 10-14.0 VOLTS (IGNITION SW AT ON POSITION)
IDL-E2	: 8.0-14.0 VOLTS (IGNITION SW ON AND THROTTLE VALVE OPEN)
VC-E2	: 4.5-5.5 VOLTS (IGNITION SW AT ON POSITION)
VTA-E2	: 0.8-1.2 VOLTS (IGNITION SW ON AND THROTTLE VALVE FULLY CLOSED) : 3.2-4.2 VOLTS (IGNITION SW ON AND THROTTLE VALVE OPEN)
PIM-E2	: 3.3-3.9 VOLTS (IGNITION SW AT ON POSITION)
VCC-E2	: 4.5-5.5 VOLTS (IGNITION SW AT ON POSITION)
#10, #20 - E01, E02	: 10-14.0 VOLTS (IGNITION SW AT ON POSITION)
THA-E2	: 1.9-2.9 VOLTS (IGNITION SW ON AND INTAKE AIR TEMP. 20°C, 68°F)
THW-E2	: 0.1-1.1 VOLTS (IGNITION SW ON AND COOLANT TEMP. 80°C, 176°F)
STA-E1	: 6.0-14.0 VOLTS (ENGINE CRANKING)
IGT-E1	: 0.8-1.2 VOLTS (ENGINE CRANKING OR IDLING)
W-E1	: 8.0-14.0 VOLTS (NO TROUBLE AND ENGINE RUNNING)
A/C-E1	: 8.0-14.0 VOLTS (IGNITION SW ON AND AIR CONDITIONING ON)
ACT-E1	: 4.5-5.5 VOLTS (IGNITION SW ON AND AIR CONDITIONING ON)
ACA-E1	: 2.0 VOLTS OR LESS (IGNITION SW ON AND AIR CONDITIONING ON)
T-E1	: 10-14.0 VOLTS (IGNITION SW ON AND CHECK CONNECTOR TE1-E1 NOT CONNECTED) : 1.0 VOLTS OR LESS (IGNITION SW ON AND CHECK CONNECTOR TE1-E1 CONNECTED)
NSW-E1	: 0-2.0 VOLTS (IGNITION SW ON AND NEUTRAL START SW POSITION P OR N RANGE) : 6.0-14.0 VOLTS (IGNITION SW ON AND EX. NEUTRAL START SW POSITION P OR N RANGE)
B/K-E1	: 10-14.0 VOLTS (BRAKE PEDAL DEPRESSED)

RESISTANCE AT ECU WIRING CONNECTORS

(DISCONNECT WIRING CONNECTOR)

IDL-E2	: INFINITY (THROTTLE VALVE OPEN) : 2.3 KΩ OR LESS (THROTTLE VALVE FULLY CLOSED)
VTA-E2	: 3.3-10.0 KΩ (THROTTLE VALVE FULLY OPEN) : 0.2-0.8 KΩ (THROTTLE VALVE FULLY CLOSED)
VC-E2	: 3.0-7.0 KΩ
THA-E2	: 2.0-3.0 KΩ (INTAKE AIR TEMP. 20°C, 68°F)
THW-E2	: 0.2-0.4 KΩ (COOLANT TEMP. 80°C, 176°F)
G1, NE - G-	: 0.17-0.21 KΩ
ISCC, ISCO+ B, +B1	: 19.3-22.3 Ω

○ : PARTS LOCATION

CODE	SEE PAGE	CODE	SEE PAGE	CODE	SEE PAGE
A17	28	F10	26 (5S-FE)	J 2	29
C 1	26 (5S-FE)	F16	30 (L/B), 31 (C/P)	J 6	29
C10	28	I 3	26 (5S-FE)	N 2	26 (5S-FE)
C13	B 28	I 4	26 (5S-FE)	O 3	26 (5S-FE)
C14	A 28	I 5	26 (5S-FE)	O 4	26 (5S-FE)
D 1	26 (5S-FE)	I 6	26 (5S-FE)	S10	29
E 2	26 (5S-FE)	I 7	26 (5S-FE)	T 1	26 (5S-FE)
E 3	26 (5S-FE)	I 8	26 (5S-FE)	V 1	26 (5S-FE)
E 6	C 29	I 9	26 (5S-FE)	V 3	26 (5S-FE)
E 7	B 29	I10	26 (5S-FE)		
E 8	A 29	I12	29		

○ : JUNCTION BLOCK AND WIRE HARNESS CONNECTOR

CODE	SEE PAGE	JUNCTION BLOCK AND WIRE HARNESS (CONNECTOR LOCATION)
1A	18	COWL WIRE AND J/B NO. 1 (LEFT KICK PANEL)
1B		
1D		
1E		
1H	18	ENGINE ROOM MAIN WIRE AND J/B NO. 1 (LEFT KICK PANEL)
2A	20	ENGINE ROOM MAIN WIRE AND J/B NO. 2 (NEAR THE BATTERY)
2B	20	ENGINE WIRE AND J/B NO. 2 (NEAR THE BATTERY)
2C		
2E	20	ENGINE ROOM MAIN WIRE AND J/B NO. 2 (NEAR THE BATTERY)
3B	22	COWL WIRE AND J/B NO. 3 (BEHIND COMBINATION METER)

 : CONNECTOR JOINING WIRE HARNESS AND WIRE HARNESS

CODE	SEE PAGE	JOINING WIRE HARNESS AND WIRE HARNESS (CONNECTOR LOCATION)
EB1	32 (5S-FE)	ENGINE WIRE AND COWL WIRE (REAR SIDE OF RIGHT FRONT FENDER)
IE1	36	ENGINE ROOM MAIN WIRE AND COWL WIRE (LEFT KICK PANEL)
IF1	36	FLOOR WIRE AND COWL WIRE (LEFT KICK PANEL)
IG2	36	ENGINE WIRE AND COWL WIRE (UNDER THE ENGINE ECU)
IJ1	36	COWL WIRE AND A/C NO. 1 WIRE (BEHIND THE GLOVE BOX)

 : GROUND POINTS

CODE	SEE PAGE	GROUND POINTS LOCATION
EB	32 (5S-FE)	FRONT LEFT FENDER
EC	32 (5S-FE)	INTAKE MANIFOLD
ID	36	LEFT KICK PANEL
BI	38 (L/B)	UNDER THE LEFT CENTER PILLAR

 : SPLICE POINTS

CODE	SEE PAGE	WIRE HARNESS WITH SPLICE POINTS	CODE	SEE PAGE	WIRE HARNESS WITH SPLICE POINTS
E 5	32 (5S-FE)	ENGINE WIRE	I 6	36	COWL WIRE
E 7			I 7	36	ENGINE WIRE
E 8			I 8	36	COWL WIRE
E 9			I10	36	CONSOLE BOX WIRE
I 5	36	COWL WIRE			