

ALTERNATOR & REGULATOR

1993 Toyota Celica

1993 ELECTRICAL
Toyota Alternators & Regulators

Celica

WARNING: Before performing service procedures on vehicle, disconnect negative battery cable. Wait at least one minute after disconnecting negative battery cable to avoid accidental air bag deployment on models so equipped.

DESCRIPTION

The alternator is a small, high RPM, high performance type with an internal Integrated Circuit (IC) voltage regulator which controls charging system voltage. A transistor inside IC regulator controls alternator voltage output to maintain a constant voltage. Charging system voltage is maintained within an operating range of 13.2-15.0 volts. See ALTERNATOR REGULATED OUTPUT SPECIFICATIONS table for specific model.

When ignition is turned on, battery voltage flows from alternator terminal "L" through IC regulator to terminal "E" and to ground, causing discharge warning light to come on. When engine starts, alternator RPM increases, which increases alternator voltage output. When alternator output voltage is greater than battery voltage, voltage to recharge battery flows from terminal "B". At the same time voltage at terminal "L" increases and the potential difference between battery and terminal "L" ceases, causing discharge warning light to go off.

TROUBLE SHOOTING

NOTE: See TROUBLE SHOOTING - BASIC PROCEDURES article in GENERAL INFORMATION section.

Check all fuses, fusible links, ignition switch, and appropriate relays (if equipped). Check alternator output test. See NO-LOAD TEST under ON-VEHICLE TESTING.

ADJUSTMENTS

NOTE: New Belt refers to a belt which has been used 5 minutes or less on a running engine. Used Belt refers to a belt which has been used more than 5 minutes on a running engine. After installing new belt(s), run engine for at least 5 minutes and recheck tension.

BELT TENSION

BELT TENSION SPECIFICATIONS TABLE (1)

Application	New Belt Lbs. (kg)	Used Belt Lbs. (kg)
1.6L 4A-FE		
Alternator	(2) 160 (73)	(2) 130 (59)
A/C	(2) 160 (73)	(2) 100 (45)
Power Steering	(3) 125 (57)	(2) 80 (36)
2.0L 3S-GTE		
Alternator With A/C	(4) 165 (75)	(2) 115 (52)

Alternator Without A/C ...	(2)	150 (68)	(3)	130 (59)
Power Steering	(3)	125 (57)	(2)	80 (36)
2.2L 5S-FE					
Alternator With A/C	(4)	165 (75)	(4)	110 (50)
Alternator Without A/C ...	(3)	125 (57)	(2)	95 (43)
Power Steering	(3)	125 (57)	(2)	80 (36)

- (1) - Measure belt tension with Burroughs (BT-33-73F) tension gauge.
- (2) - Plus or minus 20 lbs. (9 kg).
- (3) - Plus or minus 25 lbs. (11 kg).
- (4) - Plus or minus 10 lbs. (5 kg).

ON-VEHICLE TESTING

NO-LOAD TEST

1) Disconnect battery-to-alternator terminal "B" wire. See Fig. 1. Using an ammeter and voltmeter, connect negative ammeter lead to disconnected alternator terminal "B" wire end, and connect positive ammeter lead to alternator terminal "B".

2) Connect voltmeter positive lead to alternator terminal "B" and negative lead to ground. See Fig. 1.

3) Start engine and increase engine speed to 2000 RPM. Both meters should read within specification. See ALTERNATOR REGULATED OUTPUT SPECIFICATIONS table.

4) If voltage is more than specified, replace IC regulator. If voltage is less than specified, ground "F" (full field) terminal. See Fig. 2. If voltage is more than specified range, replace IC regulator. If voltage is less than specified range, repair or replace alternator.

ALTERNATOR REGULATED OUTPUT SPECIFICATIONS (1)

Application	Amps	(2) Volts
Celica	10 Or Less	(2) 14.0-15.0
Celica	10 Or Less	(3) 13.5-14.3

- (1) - Specification given is with engine speed at 2000 RPM.
- (2) - Correct reading with temperature at 77°F (25°C).
- (3) - Correct reading with temperature at 239°F (115°C).

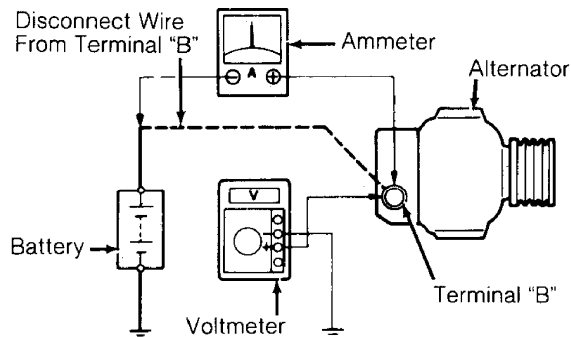

93F02148
 Fig. 1: Testing Charging Circuit
 Courtesy of Toyota Motor Sales, U.S.A., Inc.

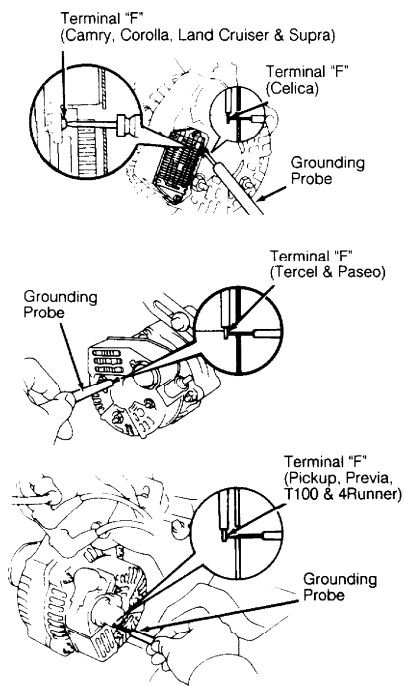

93H82153

Fig. 2: Testing Alternator Full Field Output
 Courtesy of Toyota Motor Sales, U.S.A., Inc.

LOAD TEST

NOTE: If battery is fully charged, disable ignition system. Crank engine for about 15 seconds to partially discharge battery.

1) Connect an ammeter as described in NO-LOAD TEST, step 1). See Fig. 1. Start engine. Turn on high beam headlights and place heater control on HI. Increase engine speed to 2000 RPM.

2) Check ammeter reading. Ammeter should read 30 amps or more. If amperage is less than specified, repair or replace alternator.

ALTERNATOR RATED AMPERE OUTPUT SPECIFICATIONS

Application	(1) Amperes
With A/C	80
Without A/C	70

(1) - Rated output is measured with 12 volts supplied to alternator.

BENCH TESTING

BRUSHES

Brushes should slide smoothly in holders. Replace brushes if damaged or worn. New brush exposed length should be .413" (10.5 mm). Minimum exposed length should be more than .059" (1.5 mm). There are 2 different brush holders used, one has replaceable brushes, the other brush holder is replaced as an assembly. If exposed brush length is

less than minimum replace brushes or brush holder assembly. Install new brush springs when replacing brushes.

ROTOR

1) Check rotor for open field windings by using an ohmmeter across slip rings. Rotor resistance should be 2.8-3.0 ohms.

2) Check rotor for shorts to ground by connecting ohmmeter between slip ring and rotor shaft. Ohmmeter should indicate no continuity. Check slip rings for wear or pitting. Standard slip ring diameter is .559"-.567" (14.2-14.4 mm) Turn slip rings on lathe if necessary. Minimum slip ring diameter is .504" (12.8 mm).

STATOR

Connect ohmmeter between 2 stator leads. Continuity should exist between all stator leads. Connect ohmmeter between each stator lead and metal core. Continuity should not exist. If stator does not test as indicated, replace stator.

DIODES

1) With diode/rectifier assembly removed and on bench, contact positive diode plate terminal with one ohmmeter probe. Using other ohmmeter probe, contact each of 3 diode leads in same plate. Note ohmmeter reading. Reverse ohmmeter probes, and repeat tests for all diodes.

2) All diodes should show continuity in one direction and no continuity in opposite direction. If any diode is defective, replace diode/rectifier assembly.

OVERHAUL

DISASSEMBLY

1) Remove dust cover (if equipped). Remove brush holder and IC regulator. Remove diode assembly. Remove rubber insulators or seal plate (if equipped). Use Alternator Pulley Set Nut Wrench Set (SST 09820-63010) to remove alternator pulley.

2) To remove pulley, install SST "A" and "B" to rotor shaft and tighten SST "B" clockwise to 29 ft. lbs. (39 N.m). Place SST "C" securely into a vise. Verify that SST "A" is secured to rotor shaft and install SST "A" and "B" and alternator into SST "C". See Fig. 3. Turn SST "A" in direction shown in Fig. 3 to loosen pulley nut. To prevent damage to rotor shaft, Do Not loosen pulley nut more than 1/2 turn. Remove SST "A" and "B", and alternator from SST "C". Remove SST "A" and "B" from rotor shaft and remove pulley nut and pulley.

3) Remove rectifier and frame using appropriate pulley. Remove alternator washer (if equipped). Remove rotor from drive end frame (stator).

REASSEMBLY

To assembly reverse disassembly procedures. Use Alternator Pulley Set Nut Wrench Set (SST 09820-63010) to install alternator pulley. Place SST "C" securely into a vise. Install SST "A" and "B" and alternator into SST "C". See Fig. 3. Tighten pulley nut to 81 ft. lbs. (110 N.m) in the opposite direction shown in Fig. 3. After completing assembly, verify rotor turns smoothly

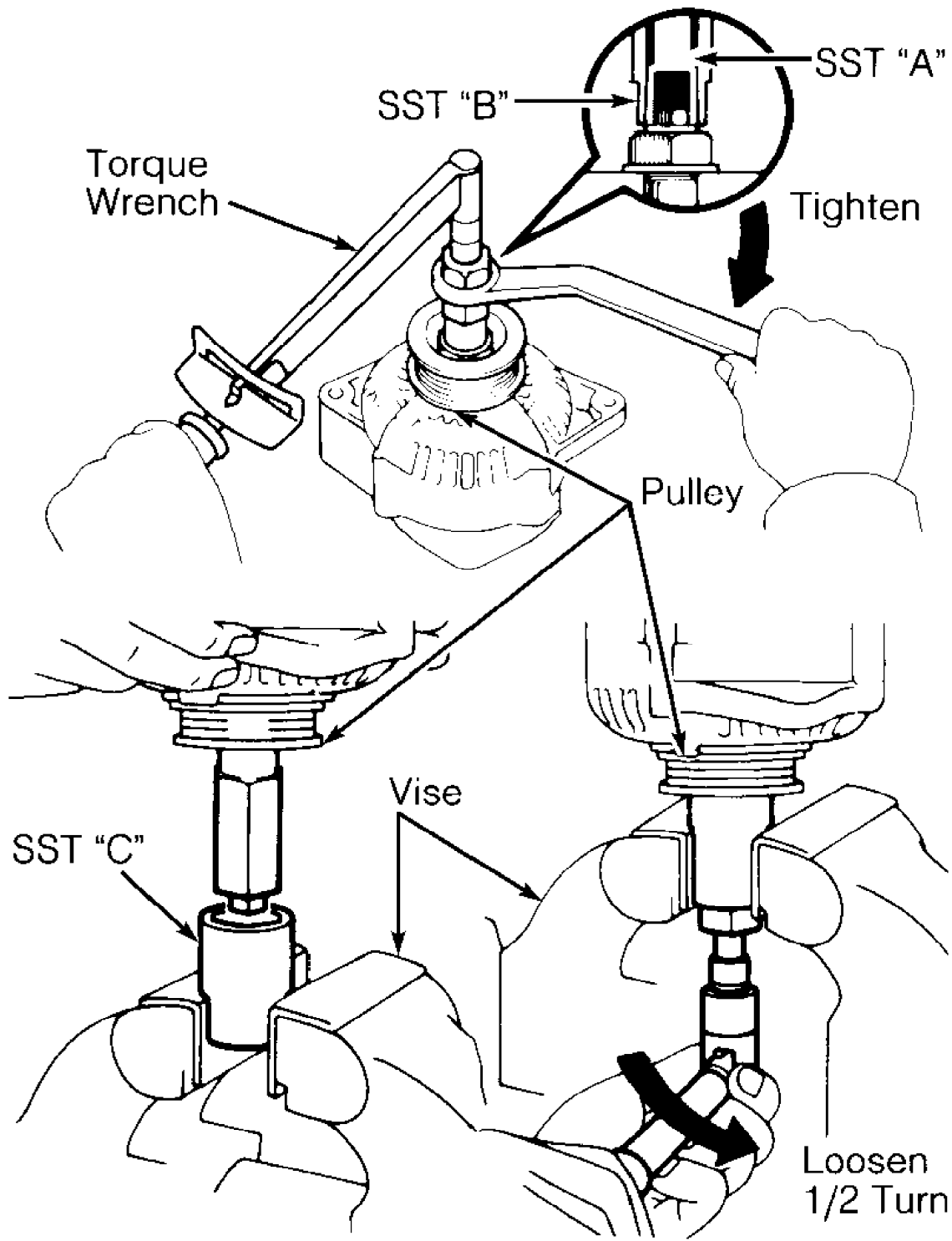

93J82155

Fig. 3: Removing Alternator Pulley
 Courtesy of Toyota Motor Sales, U.S.A., Inc.

NOTE: See Figs. 4-7 for exploded views of alternators which are similar.

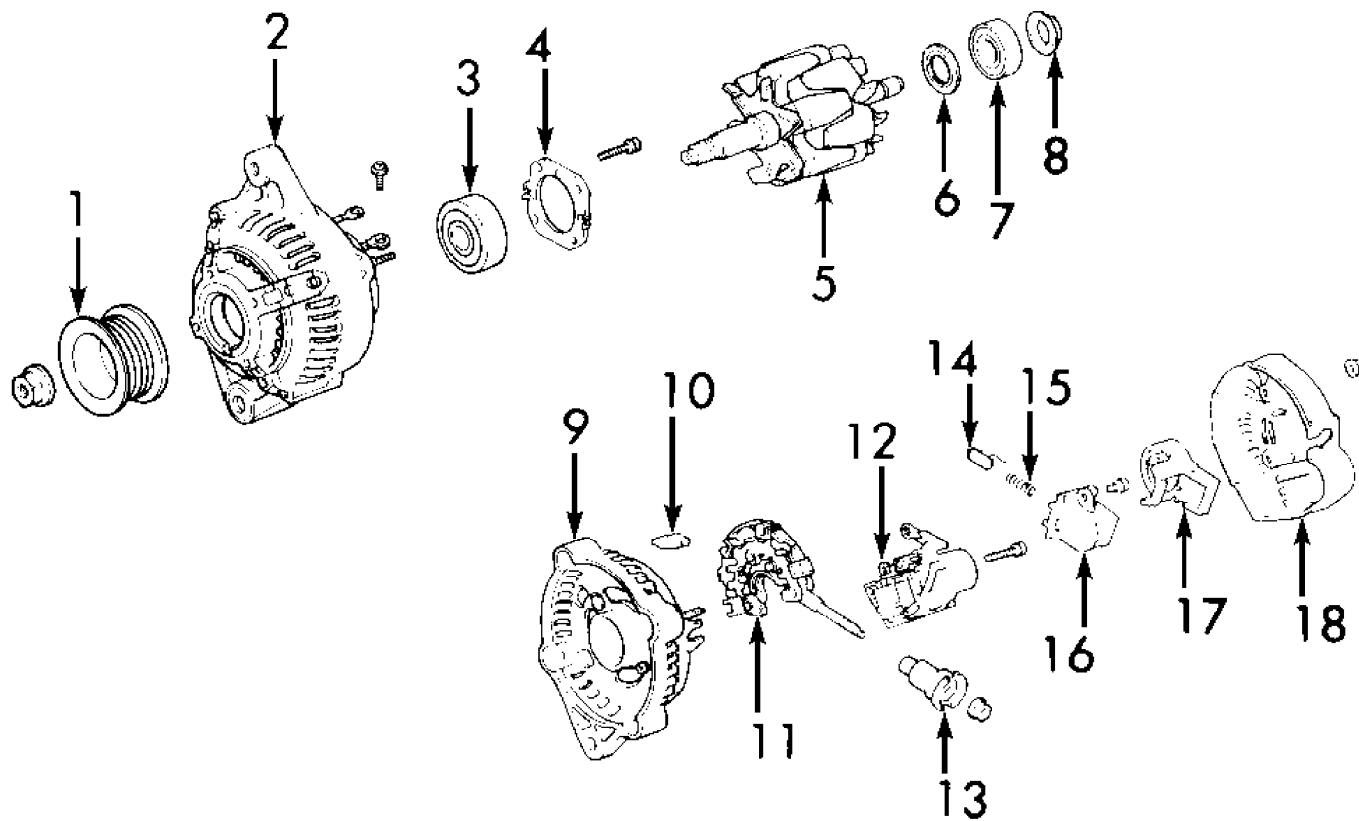

- | | |
|-----------------------------|------------------------|
| 1. Pulley | 10. Rubber Insulator |
| 2. Drive End Frame (Stator) | 11. Diode Assembly |
| 3. Front Bearing | 12. IC Regulator |
| 4. Retainer | 13. Terminal Insulator |
| 5. Rotor | 14. Brush |
| 6. Bearing Cover | 15. Spring |
| 7. Rear Bearing | 16. Brush Holder |
| 8. Bearing Cover | 17. Brush Holder Cover |
| 9. Diode End Frame | 18. Rear End Cover |

93A82156

Fig. 4: Exploded View Of Alternator (4A-FE M/T)
 Courtesy of Toyota Motor Sales, U.S.A., Inc.

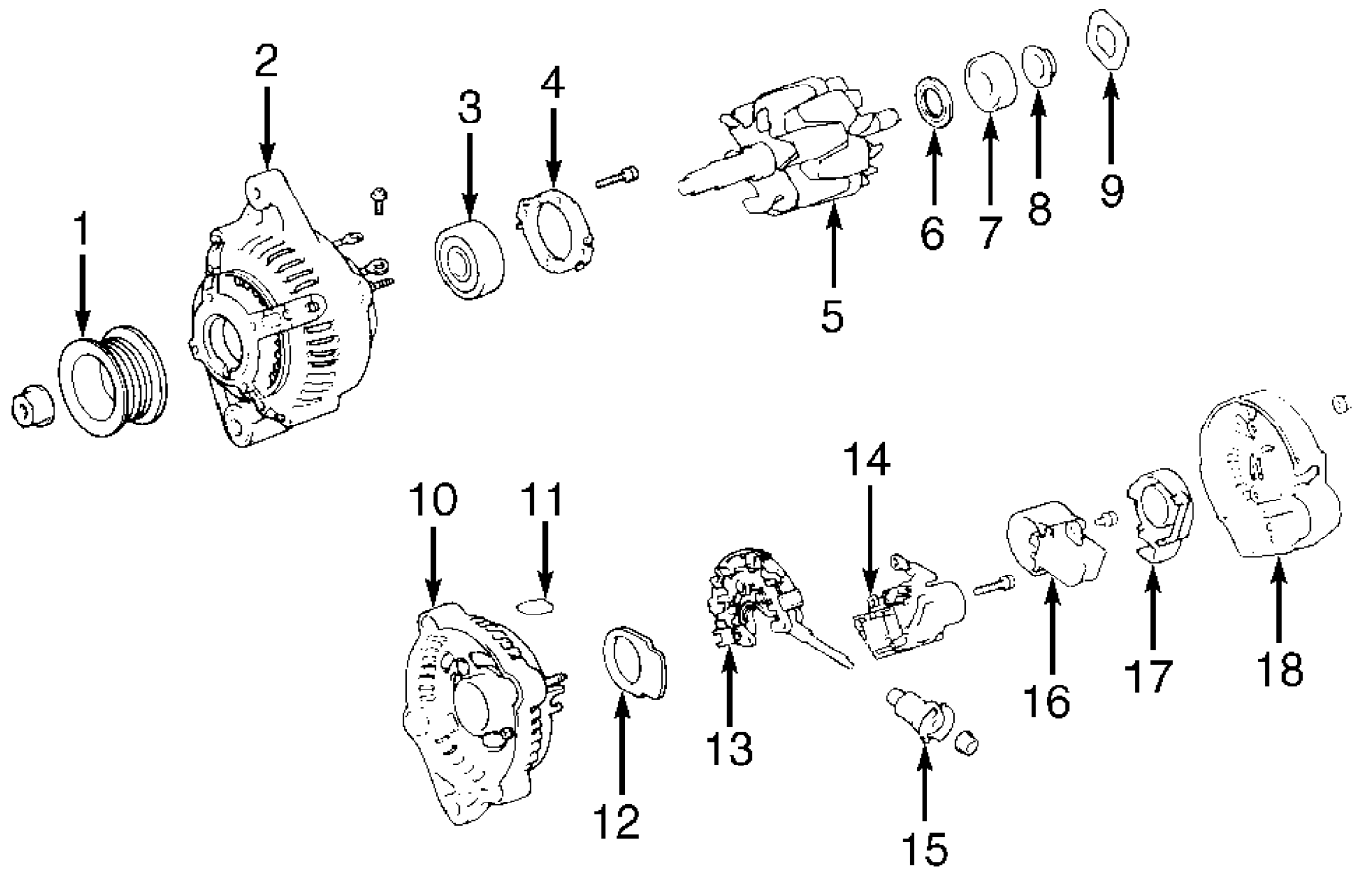

1. Pulley
2. Drive End Frame (Stator)
3. Front Bearing
4. Retainer
5. Rotor
6. Bearing Cover
7. Rear Bearing
8. Bearing Cover
9. Thrust Washer

10. Diode End Frame
11. Rubber Insulator
12. Seal Plate
13. Diode Assembly
14. IC Regulator
15. Terminal Insulator
16. Brush Holder & Brushes
17. Brush Holder Cover
18. Rear End Cover

93B82157

Fig. 5: Exploded View Of Alternator (4A-FE A/T)
 Courtesy of Toyota Motor Sales, U.S.A., Inc.

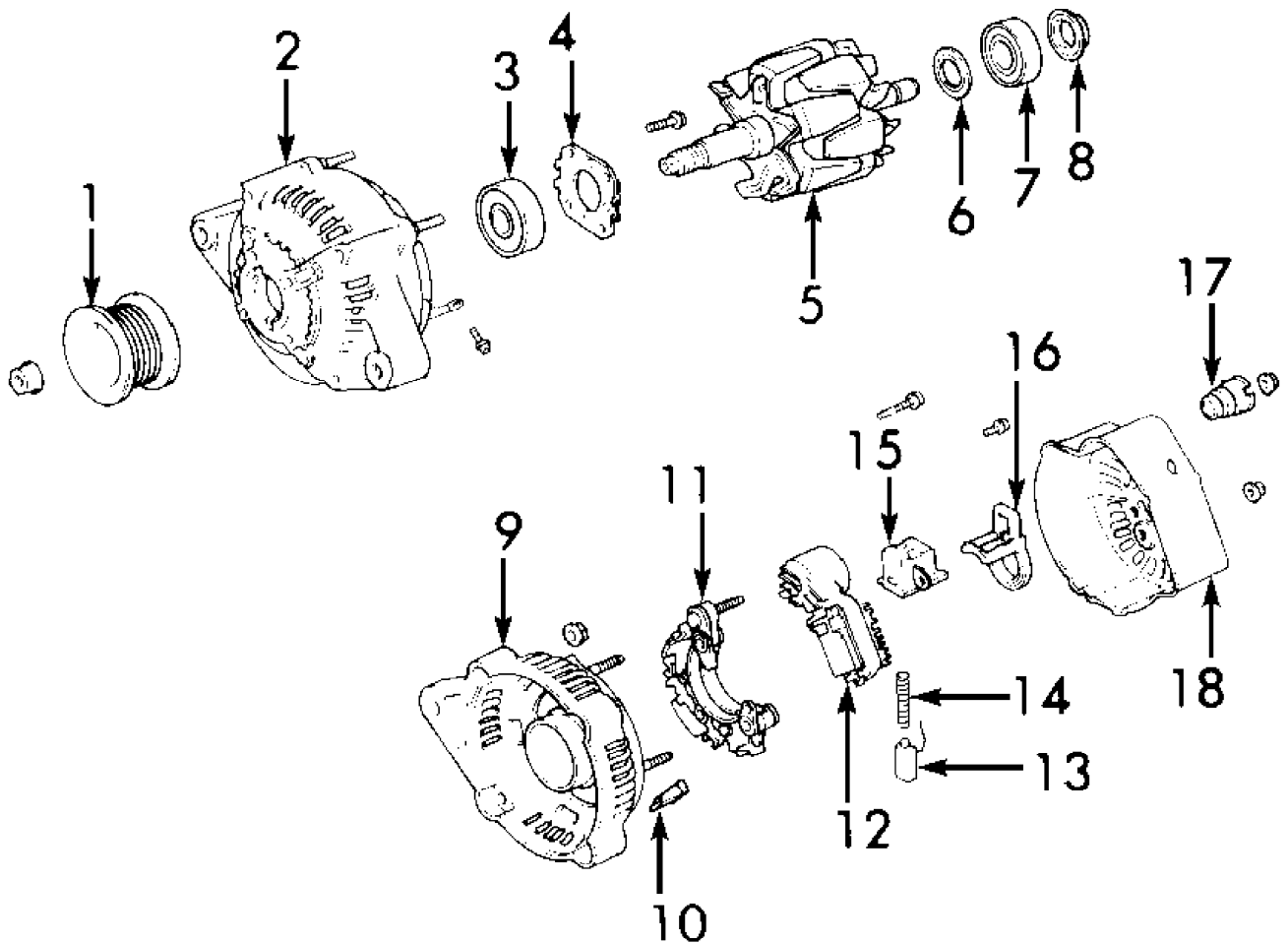

- 1. Pulley
- 2. Drive End Frame (Stator)
- 3. Front Bearing
- 4. Retainer
- 5. Rotor
- 6. Bearing Cover
- 7. Rear Bearing
- 8. Bearing Cover
- 9. Diode End Frame

- 10. Rubber Insulator
- 11. Diode Assembly
- 12. IC Regulator
- 13. Brush
- 14. Spring
- 15. Brush Holder
- 16. Brush Holder Cover
- 17. Terminal Insulator
- 18. Rear End Frame

93C82158

Fig. 6: Exploded View Of Alternator (5S-FE M/T)
 Courtesy of Toyota Motor Sales, U.S.A., Inc.

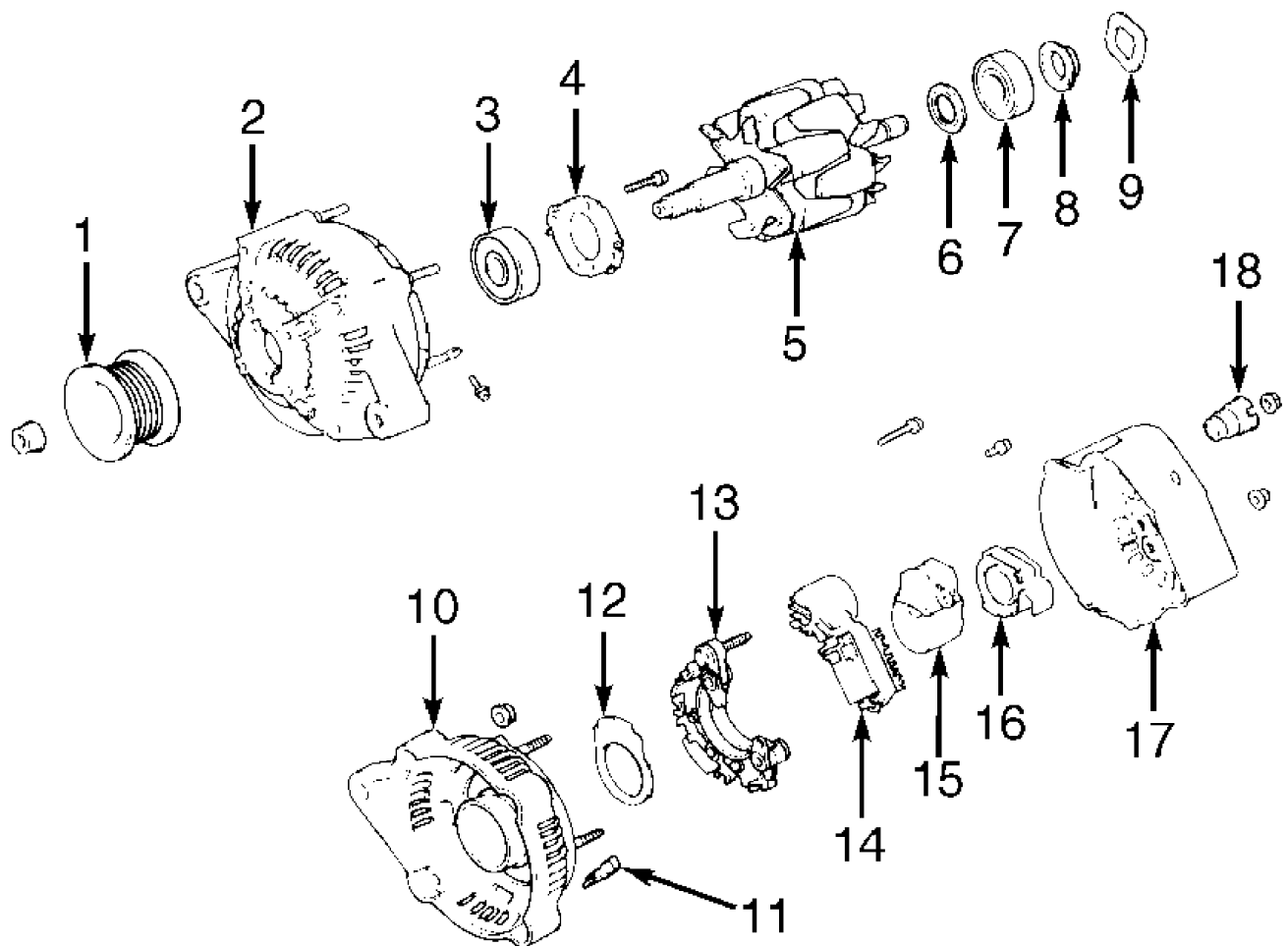

- | | |
|-----------------------------|----------------------------|
| 1. Pulley | 10. Diode End Frame |
| 2. Drive End Frame (Stator) | 11. Rubber Insulator |
| 3. Front Bearing | 12. Seal Plate |
| 4. Retainer | 13. Diode Assembly |
| 5. Rotor | 14. IC Regulator |
| 6. Bearing Cover | 15. Brush Holder & Brushes |
| 7. Rear Bearing | 16. Brush Holder Cover |
| 8. Bearing Cover | 17. Rear End Cover |
| 9. Thrust Washer | 18. Terminal Insulator |

93D82159

Fig. 7: Exploded View Of Alternator (3S-GTE & 5S-FE A/T)
 Courtesy of Toyota Motor Sales, U.S.A., Inc.

WIRING DIAGRAMS

See appropriate chassis WIRING DIAGRAMS article in WIRING
DIAGRAMS section.