

# CYLINDER HEAD (4A-FE) COMPONENTS

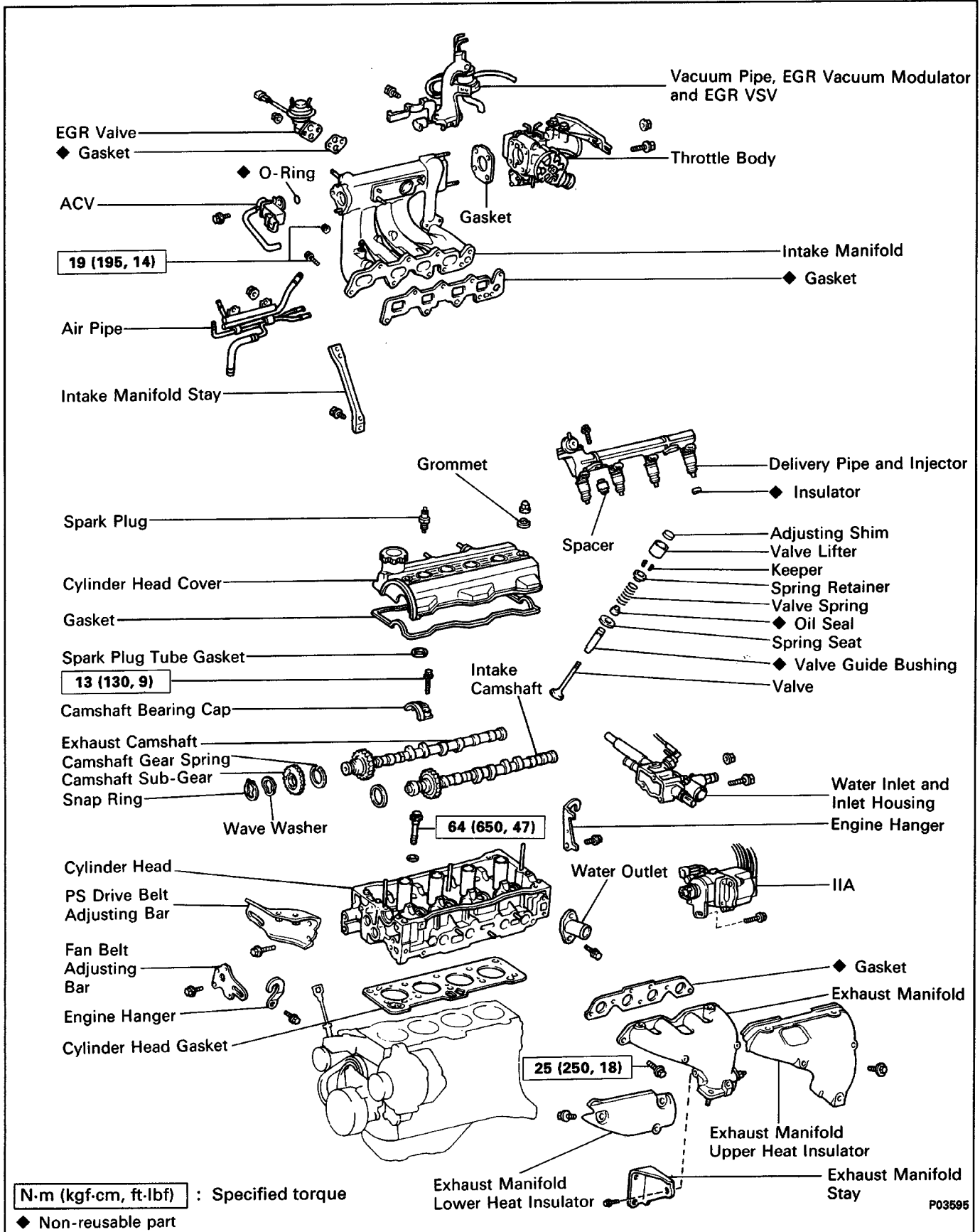

## REMOVAL OF CYLINDER HEAD

(See page [EM-81](#))

### 1. DISCONNECT CABLE FROM NEGATIVE TERMINAL OF BATTERY

**CAUTION:** Work must be started after approx. 20 seconds or longer from the time the ignition switch is turned to the "LOCK" position and the negative (-) terminal cable is disconnected from the battery.

### 2. DRAIN ENGINE COOLANT (See page [CO-6](#))

### 3. (A/T)

DISCONNECT THROTTLE CABLE FROM THROTTLE BODY

### 4. DISCONNECT ACCELERATOR CABLE FROM THROTTLE BODY

### 5. REMOVE AIR CLEANER CAP AND HOSE

(See step 6 on page [EM-185](#))

### 6. REMOVE ENGINE UNDER COVERS

### 7. REMOVE SUSPENSION LOWER CROSSMEMBER

(See step 24 on page [EM-189](#))

### 8. REMOVE FRONT EXHAUST PIPE

(See step 25 on page [EM-189](#))

### 9. REMOVE DISTRIBUTOR (See page [IG-20](#))

### 10. REMOVE EXHAUST MANIFOLD

(a) Remove the five (CALIF.) or four (Ex. CALIF.) bolts and upper heat insulator.

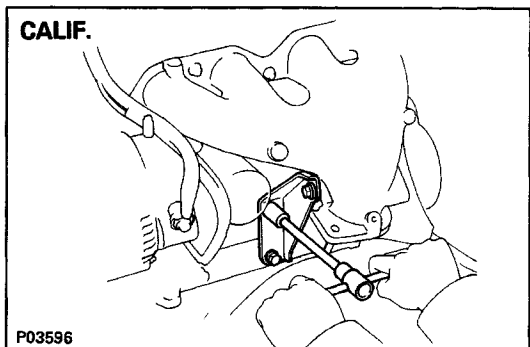
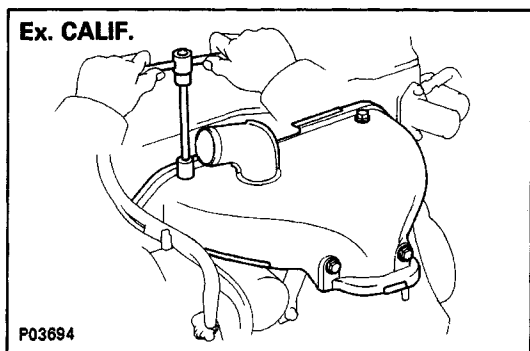
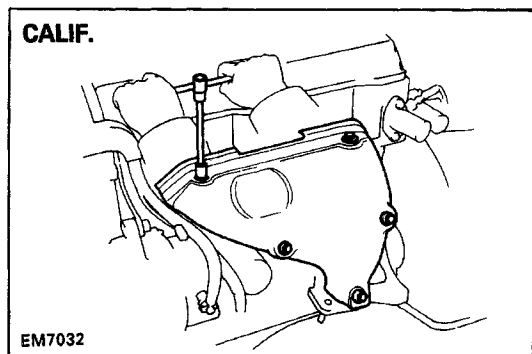

(b) Remove the three (CALIF.) or two (Ex. CALIF.) bolts and manifold stay.

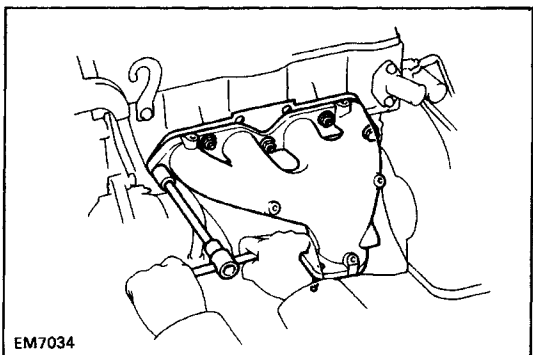
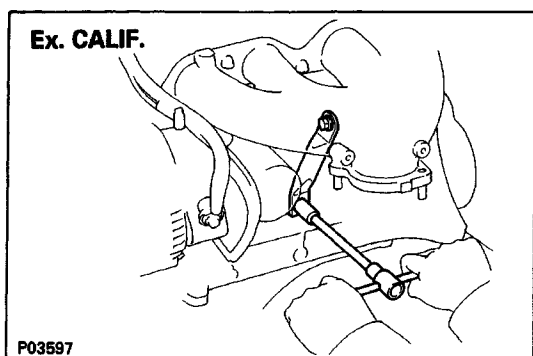

(c) Remove the two bolts, three nuts, exhaust manifold and gasket.

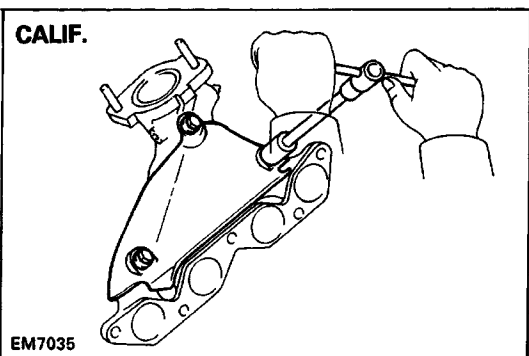

(d) Remove the three bolts and lower heat insulator from the exhaust manifold.

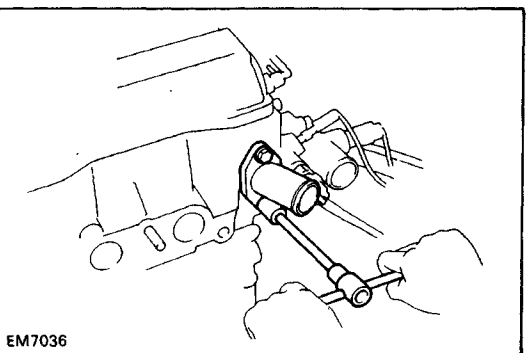
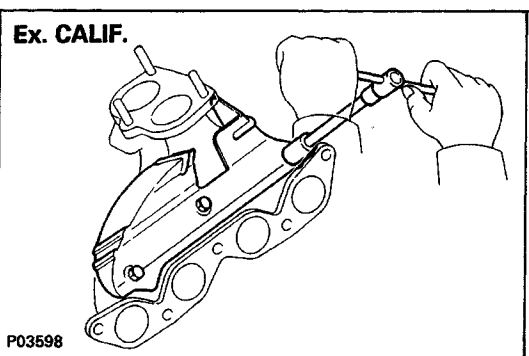

## 11. REMOVE WATER OUTLET

- (a) Disconnect the upper radiator hose from the water outlet.
- (b) Remove the two bolts and water outlet.

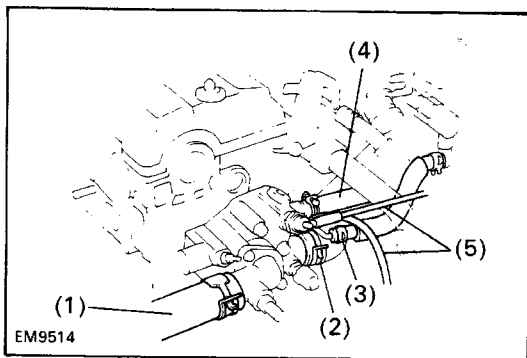

## 12. REMOVE WATER INLET AND INLET HOUSING

- (a) Disconnect the following connectors:
  - Water temperature sender gauge connector
  - Water temperature sensor connector
- (b) Disconnect the following hoses:
  - (1) Lower radiator hose
  - (2) Inlet pipe water hose
  - (3) Auxiliary air valve water by-pass hose
  - (4) Heater water hose
  - (5) Two EVAP BSVS vacuum hoses
- (c) Remove the bolt, two nuts, the water inlet and inlet housing assembly.

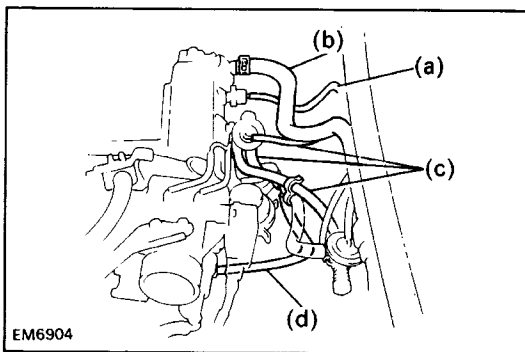
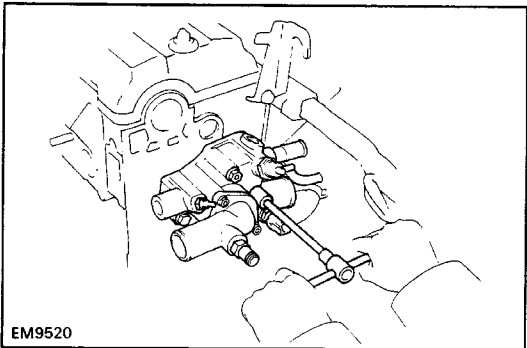

## 13. DISCONNECT VACUUM HOSES

- (a) Vacuum sensor hose from gas filter on intake manifold
- (b) Brake booster vacuum hose from intake manifold
- (c) Three A/C vacuum hoses from ASV on intake manifold
- (d) A/C vacuum hose from air pipe

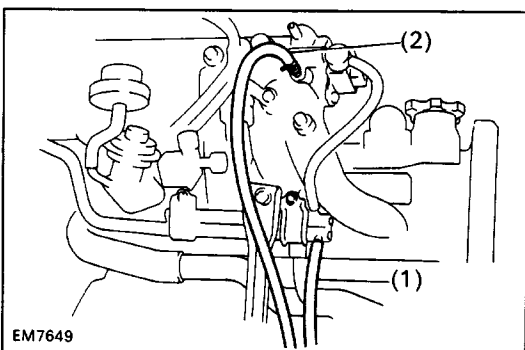

## 14. REMOVE PS PUMP WITHOUT DISCONNECTING HOSES

- (a) Disconnect the following hoses:
  - (1) Air hose from air pipe
  - (2) Air hose from intake manifold
- (b) Loosen the bolt holding the PS pump to the PS pump bracket.
- (c) Remove the bolt holding the PS pump to the PS drive belt adjusting strut, and disconnect the drive belt from the PS pump pulley.
- (d) Disconnect the PS pump from the adjusting strut.

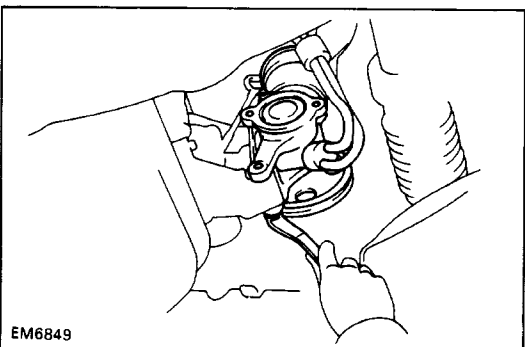

## 15. REMOVE THROTTLE BODY

(See steps 6, 8 and 9 on pages [FI-188](#) and 189)

## 16. REMOVE DELIVERY PIPE AND INJECTORS

(See steps 2 to 6 on page [FI-156](#))

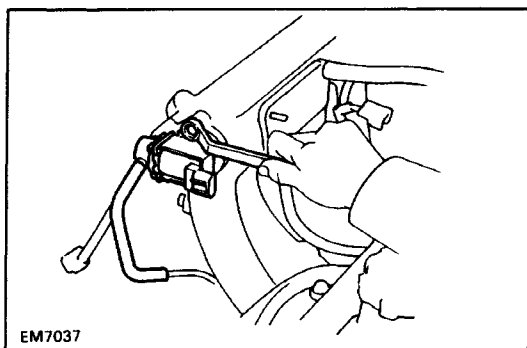
**17. REMOVE ACV**

- (a) Disconnect the air hose from the air pipe.
- (b) Remove the bolt, nut and ACV.
- (c) Remove the O-ring from the ACV.

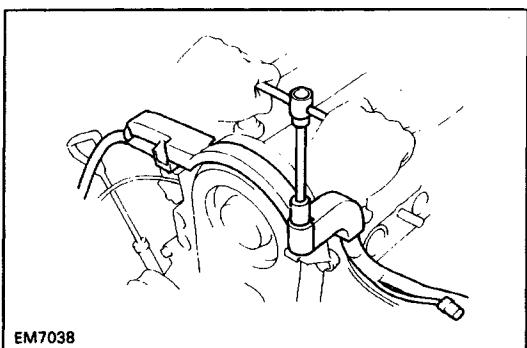
**18. DISCONNECT ENGINE WIRE FROM NO.3 TIMING BELT COVER**

- (a) Disconnect the following connectors and wire:
  - Alternator connector
  - Alternator wire
  - Oil pressure switch connector
  - A/C compressor connector
- (b) Remove the bolt.
- (c) Disconnect the wire clamp from the wire bracket, and disconnect the engine wire from the timing belt cover.

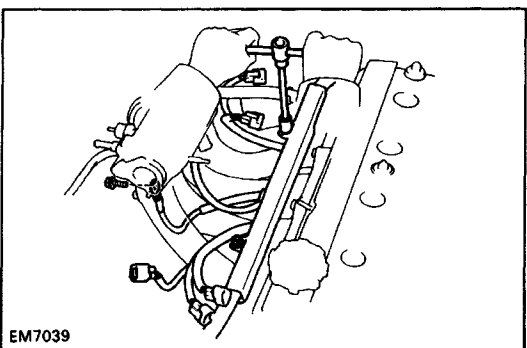
**19. DISCONNECT ENGINE WIRE FROM INTAKE MANIFOLD**

- (a) Disconnect the following connectors:
  - EGR VSV connector
  - (CALIF. only)  
EGR gas temperature sensor connector
  - Vacuum sensor connector
- (b) Disconnect the wire clamp from the vacuum pipe.
- (c) Remove the three bolts, and disconnect the engine wire from the intake manifold.

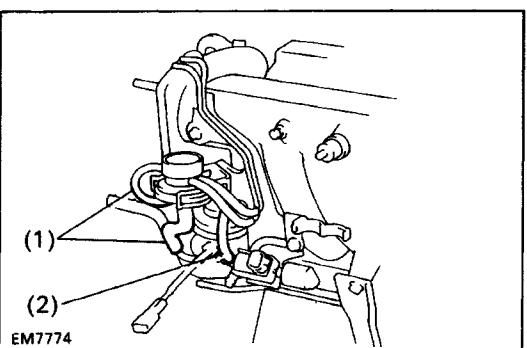
**20. REMOVE VACUUM PIPE, EGR VACUUM MODULATOR AND EGR VSV**

- (a) Disconnect the following hoses:
  - (1) Two vacuum hoses from EGR valve
  - (2) Vacuum hose from EGR VSV

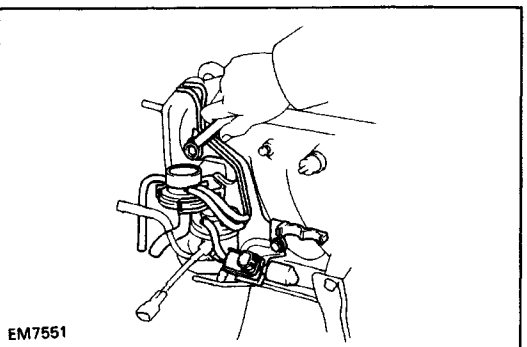

- (b) Remove the two nuts, the vacuum pipe, vacuum modulator and VSV assembly.

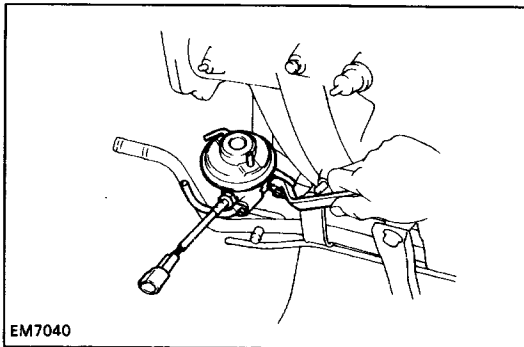
**21. REMOVE EGR VALVE**

Remove the two nuts, EGR valve and gasket.

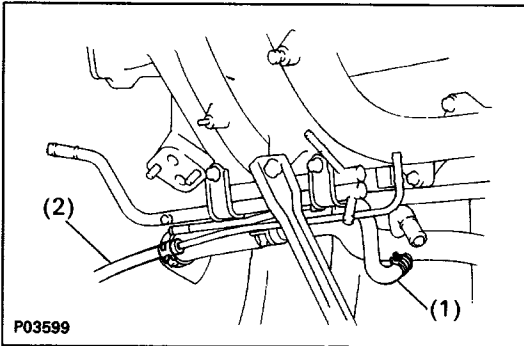
**22. REMOVE AIR PIPE**

- (a) Disconnect the following hoses:
- (1) Water inlet pipe hose
  - (2) Fuel return hose (from fuel filter)

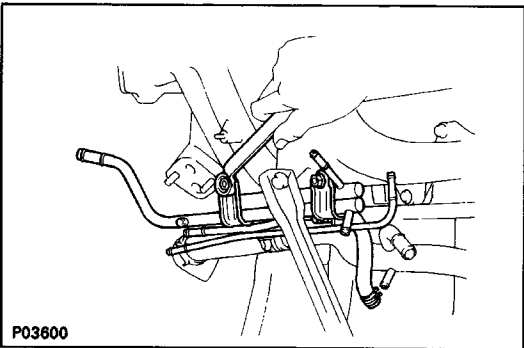

- (b) Remove the two nuts and air pipe.

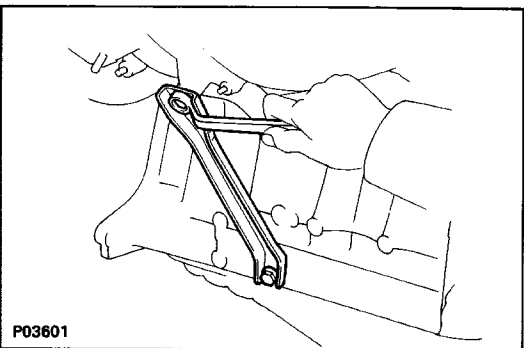
**23. REMOVE INTAKE MANIFOLD**

- (a) Remove the two bolts and manifold stay.

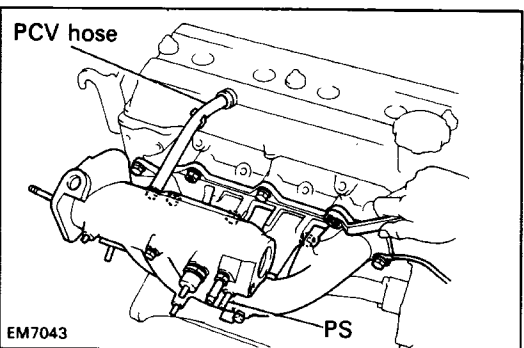

- (b) Disconnect the PCV hose from the PCV valve on the cylinder head.
- (c) Remove the seven bolts, two nuts, intake manifold and gasket.

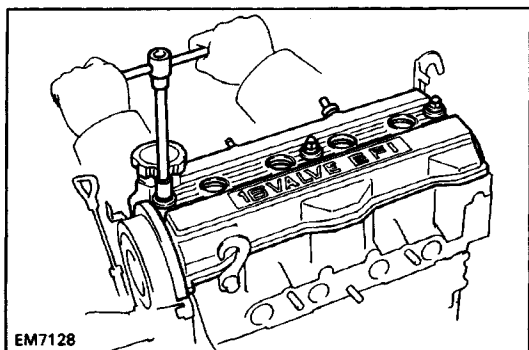
**24. REMOVE CYLINDER HEAD COVER**

Remove the three cap nuts, grommets, head cover and gasket.

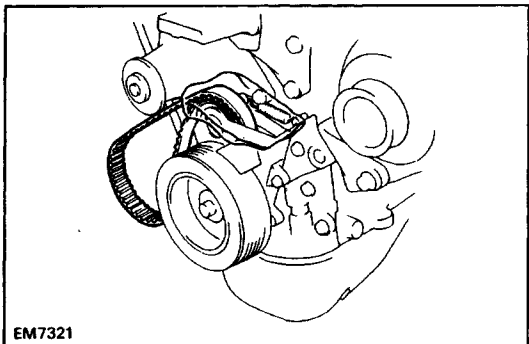
**25. DISCONNECT TIMING BELT FROM CAMSHAFT TIMING PULLEY**

(See steps 2 and 4 to 15 on pages [EM-33](#) to 36)

**NOTICE:**

- Support the timing belt, so the meshing of the crankshaft timing pulley and timing belt does not shift.
- Be careful not to drop anything inside the timing belt cover.
- Do not allow the belt to come into contact with oil, water or dust.

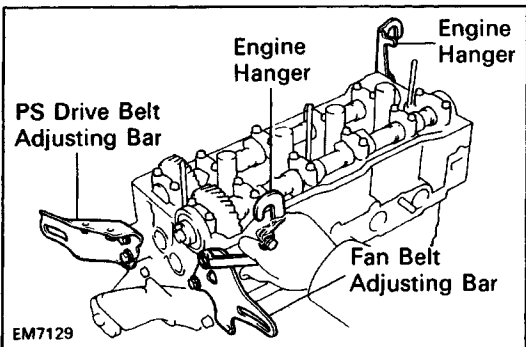
**26. REMOVE CAMSHAFT TIMING PULLEY**  
(See step 16 on page [EM-36](#))**27. REMOVE FAN BELT ADJUSTING BAR**

Remove the two bolts and adjusting bar.

**28. REMOVE ENGINE HANGERS**

Remove the bolt and engine hanger. Remove the two engine hangers.

**29. REMOVE PS DRIVE BELT ADJUSTING STRUT**

Remove the two bolts and adjusting strut.

**30. REMOVE CAMSHAFTS**

**NOTICE:** Since the thrust clearance of the camshaft is small, the camshaft must be kept level while it is being removed. If the camshaft is not kept level, the portion of the cylinder head receiving the shaft thrust may crack or be damaged, causing the camshaft to seize or break. To avoid this, the following steps should be carried out.

**A. Remove intake camshaft**

(a) Set the intake camshaft so the knock pin is slightly above the top of the cylinder head.

**HINT:** The above angle allows the No.1 and No.3 cylinder cam lobes of the intake camshaft to push their valve lifters evenly.

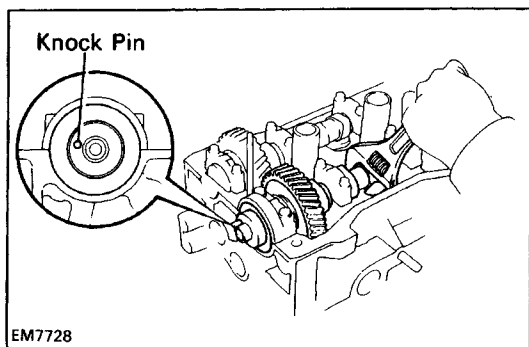

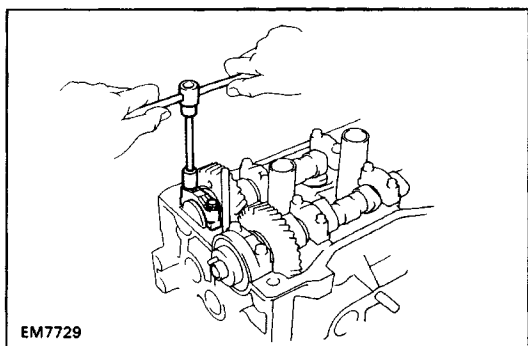

(b) Remove the two bolts and front bearing cap.

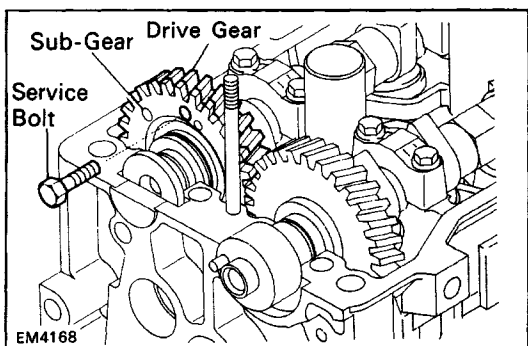

(c) Secure the intake camshaft sub-gear to the drive gear with a service bolt.

Recommended service bolt:

Thread diameter 6 mm

Thread pitch 1.0 mm

Bolt length 16 – 20 mm (0.63 – 0.79 in.)

HINT: When removing the camshaft, make sure that the torsional spring force of the sub-gear has been eliminated by the above operation.

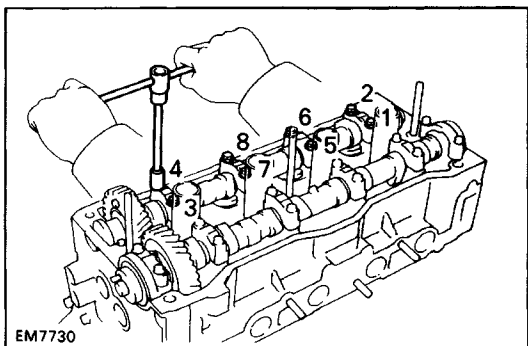

(d) Uniformly loosen and remove the eight bearing cap bolts in several passes in the sequence shown.

(e) Remove the four bearing caps and camshaft.

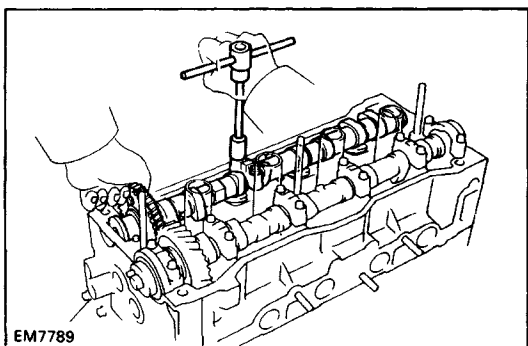

HINT: If the camshaft is not being lifted out straight and level, reinstall the bearing cap with the two bolts.

Then alternately loosen and remove the bearing cap bolts with the camshaft gear pulled up.

**NOTICE: Do not pry on or attempt to force the camshaft with a tool or other object.**

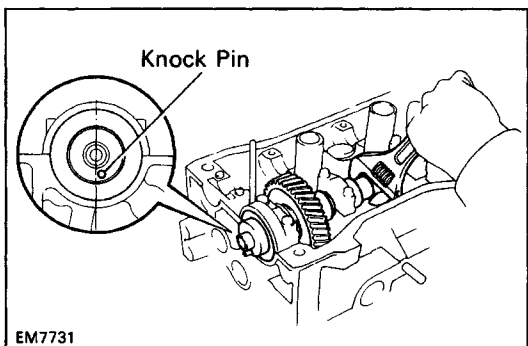

## B. Remove exhaust camshaft

(a) Set the intake camshaft so the knock pin is located slightly counterclockwise from the vertical axis of the camshaft.

HINT: The above angle allows the No. 1 and No. 3 cylinder cam lobes of exhaust camshaft to push their valve lifters evenly.



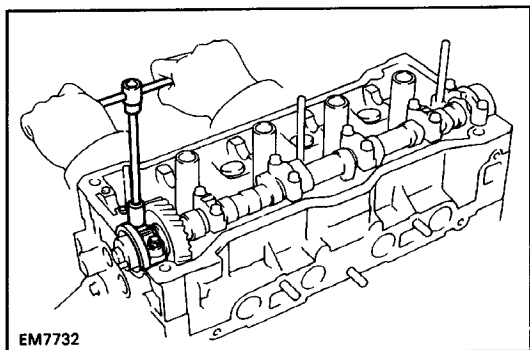

- (b) Remove the two bolts, front bearing cap and oil seal.

**NOTICE:** If the front bearing cap is not removable by hand, do not try to remove by force but leave as it is without bolts.

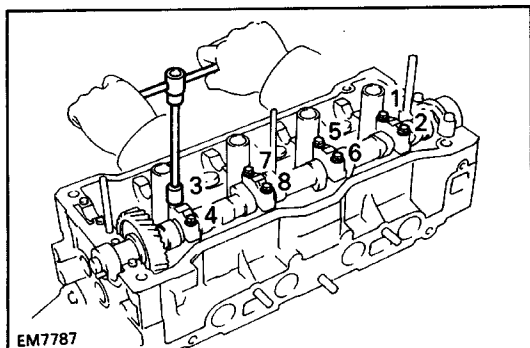

- (c) Uniformly loosen and remove the eight bearing cap bolts in several passes in the sequence shown.  
 (d) Remove the four bearing caps and camshaft.

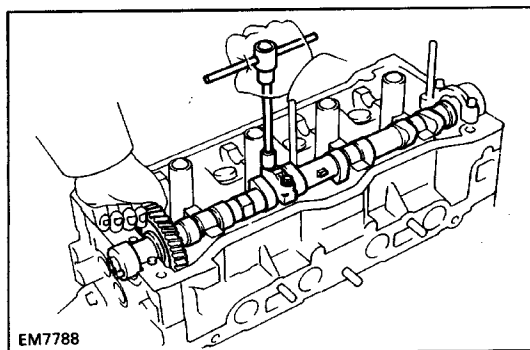

- HINT:** If the camshaft is not being lifted out straight and level, reinstall the No.3 bearing cap with the two bolts. Then alternately loosen and remove the two bearing cap bolts with the camshaft gear pulled up.

**NOTICE:** Do not pry on or attempt to force the camshaft with a tool or other object.

### 31. DISASSEMBLE EXHAUST CAMSHAFT

- (a) Mount the hexagon wrench head portion of the camshaft in a vise.

**NOTICE:** Be careful not to damage the camshaft.

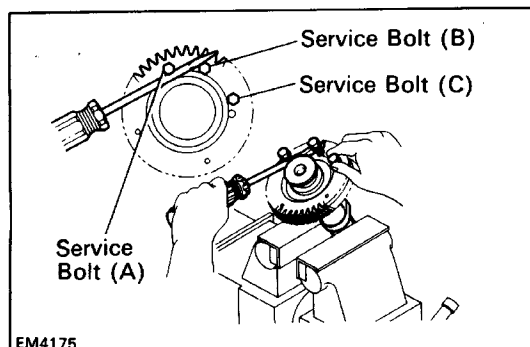
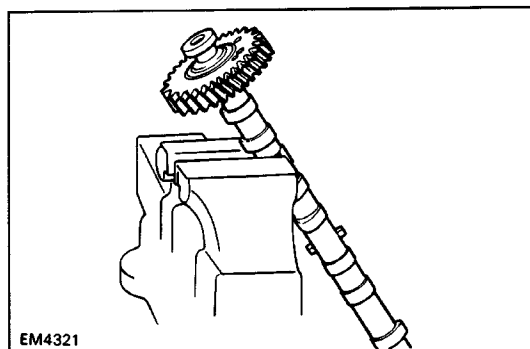

- (b) Insert service bolts (A) and (B) into the service holes of the camshaft sub-gear.  
 (c) Using a screwdriver, turn the sub-gear clockwise, and remove the service bolt (C).

**NOTICE:** Be careful not to damage the camshaft.

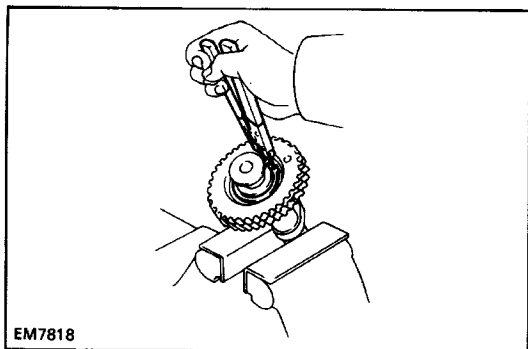

(d) Using snap ring pliers, remove the snap ring.

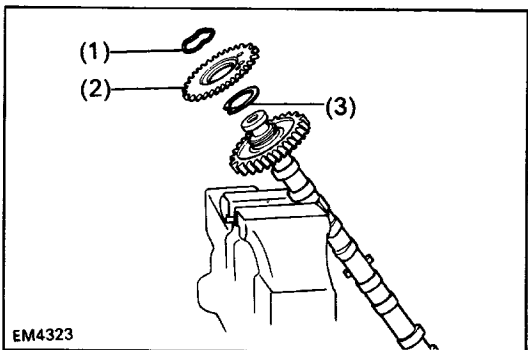

(e) Remove the following parts:

- (1) Wave washer
- (2) Camshaft sub-gear
- (3) Camshaft gear spring

### 32. REMOVE SEMI-CIRCULAR PLUG

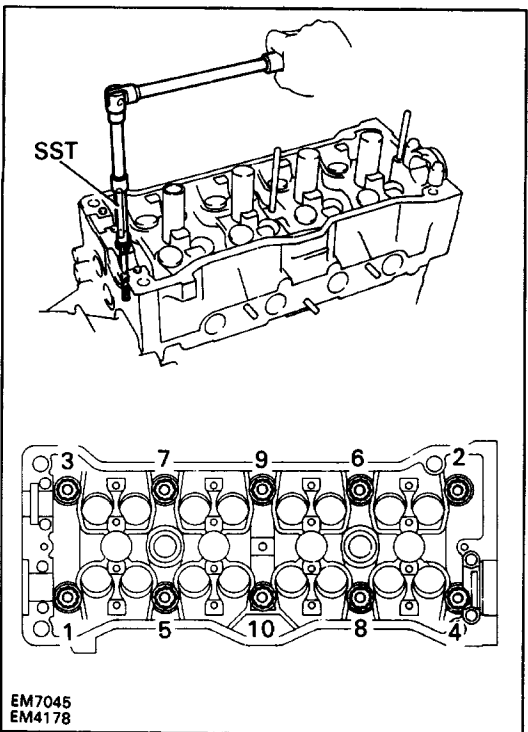

### 33. REMOVE CYLINDER HEAD

(a) Using SST, uniformly loosen and remove the ten cylinder head bolts in several passes in the sequence shown.

SST 09205-16010

**NOTICE: Cylinder head warpage or cracking could result from removing bolts in incorrect order.**

(b) Remove the ten plate washers.

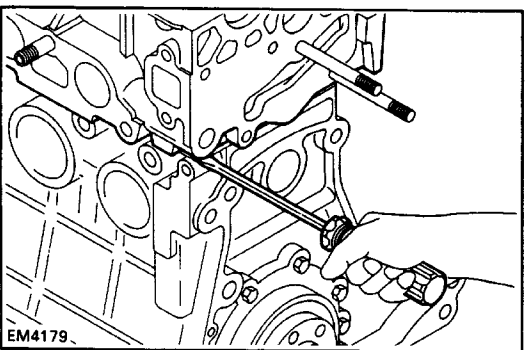

(c) Lift the cylinder head from the dowels on the cylinder block and place the head on wooden blocks on a bench.

HINT: If the cylinder head is difficult to lift off, pry with a screwdriver between the cylinder head and block saliences.

**NOTICE: Be careful not to damage the contact surfaces of the cylinder head and cylinder block.**

## DISASSEMBLY OF CYLINDER HEAD

(See page EM-81)

### 1. REMOVE VALVE LIFTERS AND SHIMS

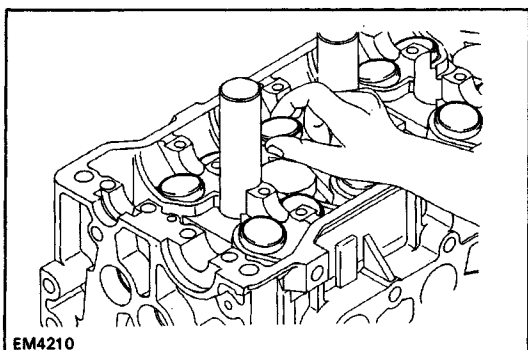

HINT: Arrange the valve lifters and shims in correct order.

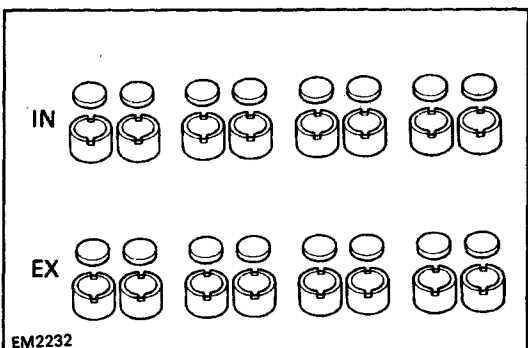

### 2. REMOVE VALVES

(a) Using SST, compress the valve spring and remove the two keepers.

SST 09202-70010

(b) Remove the spring retainer, valve spring, valve and spring seat.

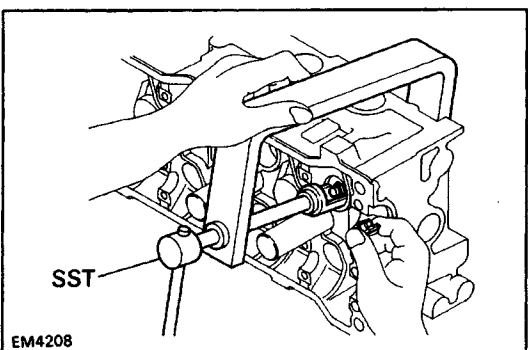

HINT: Arrange the valves, valve springs, spring seats and spring retainers in correct order.

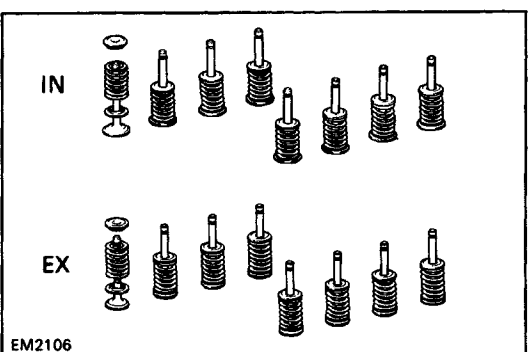

(c) Using needle-nose pliers, remove the oil seal.

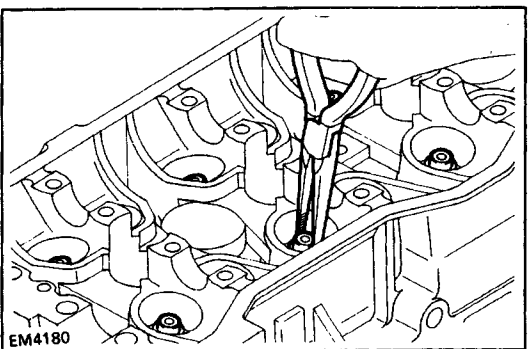

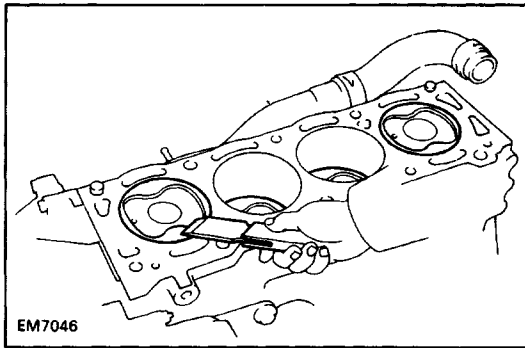

## INSPECTION, CLEANING AND REPAIR OF CYLINDER HEAD COMPONENTS

### 1. CLEAN TOP SURFACES OF PISTONS AND CYLINDER BLOCK

- (a) Turn the crankshaft and bring each piston to top dead center (TDC). Using a gasket scraper, remove all the carbon from the piston top surfaces.

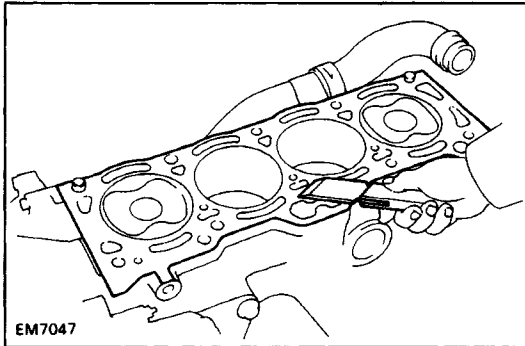

- (b) Using a gasket scraper, remove all the gasket material from the surface contacting the cylinder head.

- (c) Using compressed air, blow carbon and oil from the bolt holes.

**CAUTION:** Protect your eyes when using high-pressure compressed air.

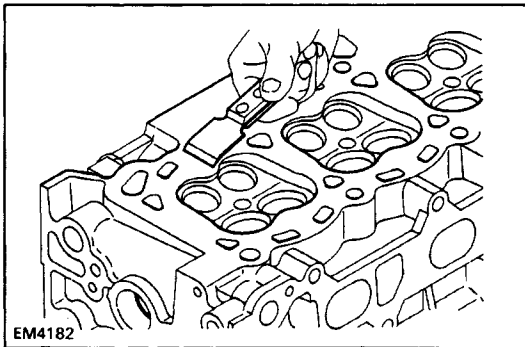

### 2. CLEAN CYLINDER HEAD

#### A. Remove gasket material

Using a gasket scraper, remove all the gasket material from the surface contacting the cylinder block.

**NOTICE:** Be careful not to scratch the cylinder block contact surface.

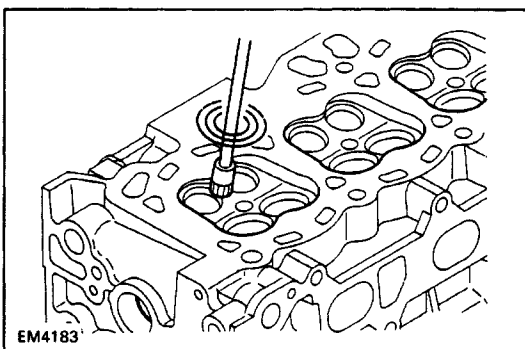

#### B. Clean combustion chambers

Using a wire brush, remove all the carbon from the combustion chambers.

**NOTICE:** Be careful not to scratch the cylinder block contact surface.

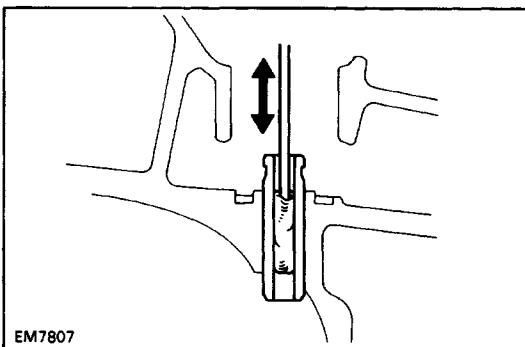

#### C. Clean valve guide bushings

Using a valve guide bushing brush and solvent, clean all the guide bushings.

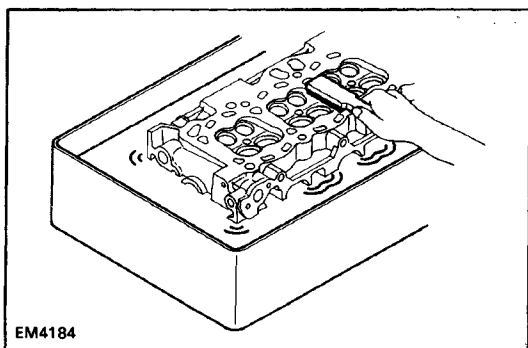

EM4184

- D. Clean cylinder head  
Using a soft brush and solvent, thoroughly clean the cylinder head.

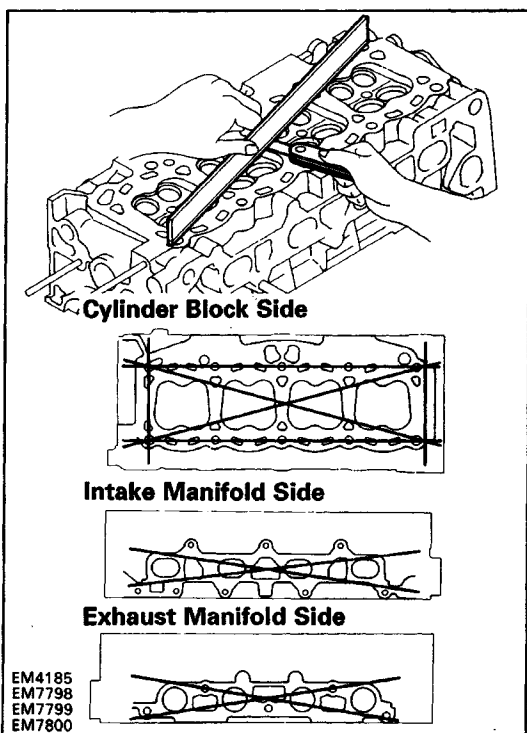
EM4185  
EM7798  
EM7799  
EM7800

### 3. INSPECT CYLINDER HEAD

#### A. Inspect for flatness

Using precision straight edge and feeler gauge, measure the surfaces contacting the cylinder block and manifolds for warpage.

#### Maximum warpage:

Cylinder block side 0.05 mm (0.0020 in.)

Manifold side 0.10 mm (0.0039 in.)

If warpage is greater than maximum, replace the cylinder head.

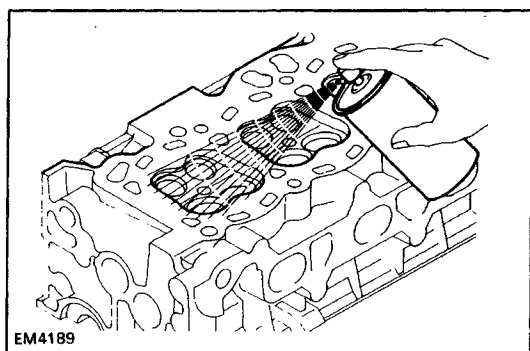

EM4189

#### B. Inspect for cracks

Using a dye penetrant, check the combustion chambers, intake ports, exhaust ports and cylinder block surface for cracks.

If cracked, replace the cylinder head.

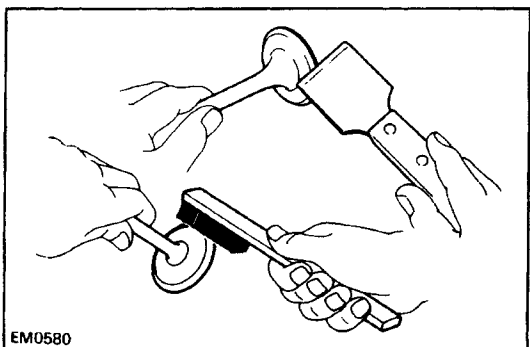

EM0580

### 4. CLEAN VALVES

- (a) Using a gasket scraper, chip off any carbon from the valve head.
- (b) Using a wire brush, thoroughly clean the valve.

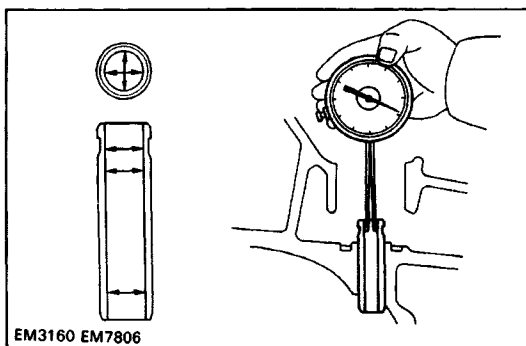

## 5. INSPECT VALVE STEMS AND GUIDE BUSHINGS

- (a) Using a caliper gauge, measure the inside diameter of the guide bushing.

**Bushing inside diameter:**

**6.010 – 6.030 mm (0.2366 – 0.2374 in.)**

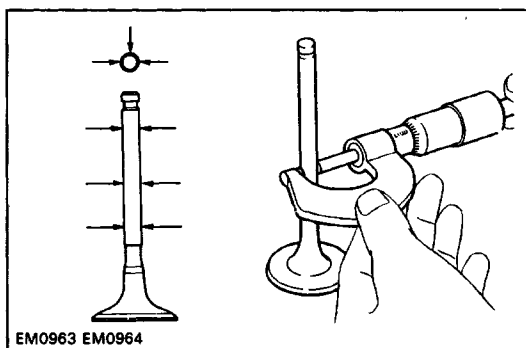

- (b) Using a micrometer, measure the diameter of the valve stem.

**Valve stem diameter:**

**Intake            5.970 – 5.985 mm  
(0.2350 – 0.2356 in.)**

**Exhaust         5.965 – 5.980 mm  
(0.2348 – 0.2354 in.)**

- (c) Subtract the valve stem diameter measurement from the guide bushing inside diameter measurement.

**Standard oil clearance:**

**Intake            0.025 – 0.060 mm  
(0.0010 – 0.0024 in.)**

**Exhaust         0.030 – 0.065 mm  
(0.0012 – 0.0026 in.)**

**Maximum oil clearance:**

**Intake            0.08 mm (0.0031 in.)**

**Exhaust         0.10 mm (0.0039 in.)**

If the clearance is greater than maximum, replace the valve and guide bushing.

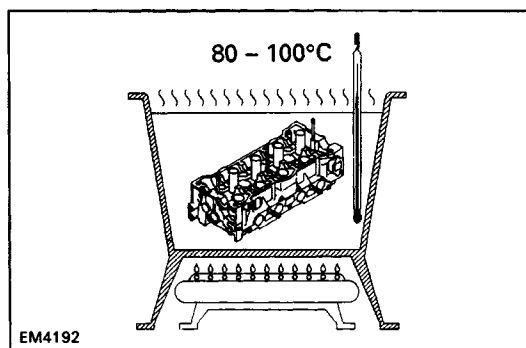

## 6. IF NECESSARY, REPLACE VALVE GUIDE BUSHINGS

- (a) Gradually heat the cylinder head to 80 – 100°C (176 – 212°F).

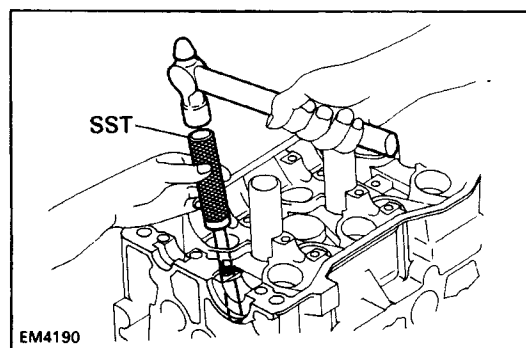

- (b) Using SST and a hammer, tap out the guide bushing.

**SST 09201-70010**

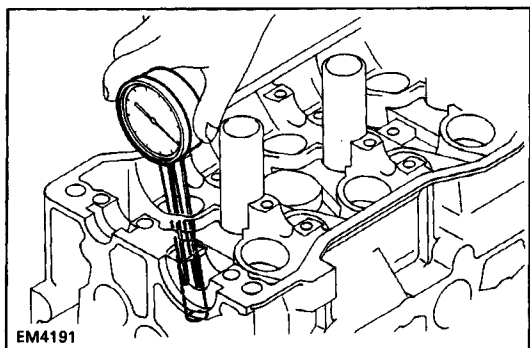

- (c) Using a caliper gauge, measure the bushing bore diameter of the cylinder head.

Both intake and exhaust

Bushing bore diameter mm (in.)	Bushing size
11.000 – 11.027 (0.4331 – 0.4342)	Use STD
11.050 – 11.077 (0.4350 – 0.4361)	Use O/S 0.05

- (d) Select a new guide bushing (STD or O/S 0.05). If the bushing bore diameter of the cylinder head is greater than 11.027 mm (0.4341 in.), machine the bushing bore to the following dimension:

**11.050 – 11.077 mm (0.4350 – 0.4361 in.)**

- If the bushing bore diameter of the cylinder head is greater than 11.077 mm (0.4361 in.), replace the cylinder head.

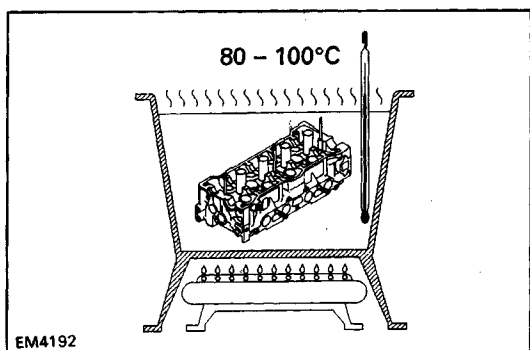

- (e) Gradually heat the cylinder head to 80 – 100°C (176 – 212°F).

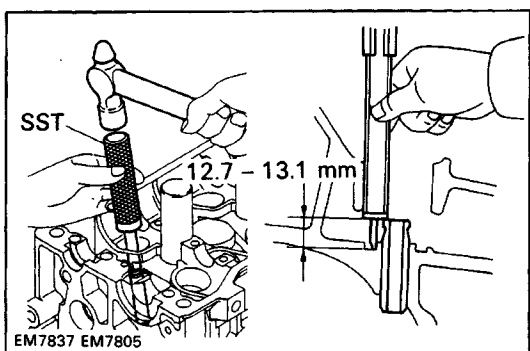

- (f) Using SST and a hammer, tap in a new guide bushing until there is 12.7 – 13.1 mm (0.500 – 0.516 in.) protruding from the cylinder head.

SST 09201-70010

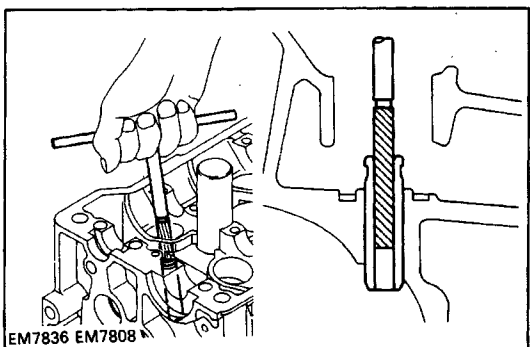

- (g) Using a sharp 6 mm reamer, ream the guide bushing to obtain the standard specified clearance (See page [EM-94](#)) between the guide bushing and valve stem.

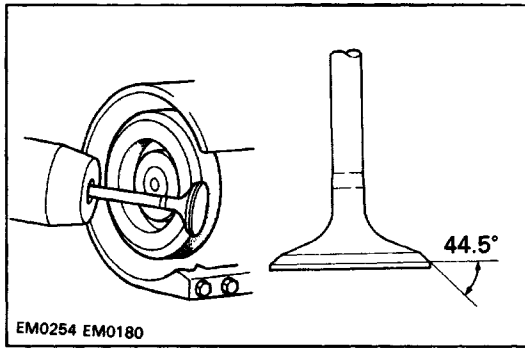

## 7. INSPECT AND GRIND VALVES

- (a) Grind the valve enough to remove pits and carbon.
- (b) Check that the valve is ground to the correct valve face angle.

**Valve face angle: 44.5°**

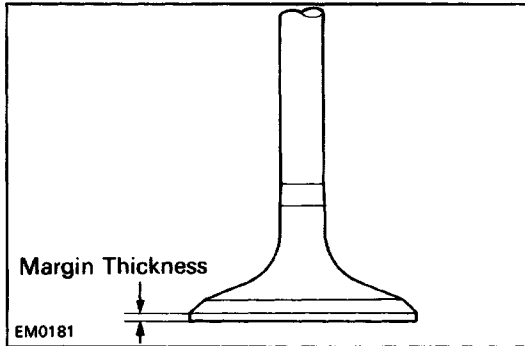

- (c) Check the valve head margin thickness.

**Standard margin thickness: 0.8 – 1.2 mm**

**(0.031 – 0.047 in.)**

**Minimum margin thickness: 0.5 mm (0.020 in.)**

If the margin thickness is less than minimum, replace the valve.

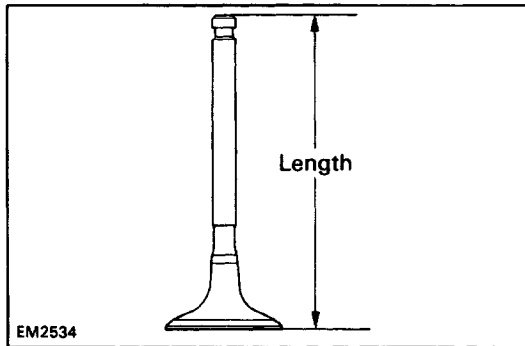

- (d) Check the valve overall length.

**Standard overall length:**

**Intake 91.45 mm (3.6004 in.)**

**Exhaust 91.90 mm (3.6181 in.)**

**Minimum overall length:**

**Intake 90.95 mm (3.5807 in.)**

**Exhaust 91.40 mm (3.5984 in.)**

If the overall length is less than minimum, replace the valve.

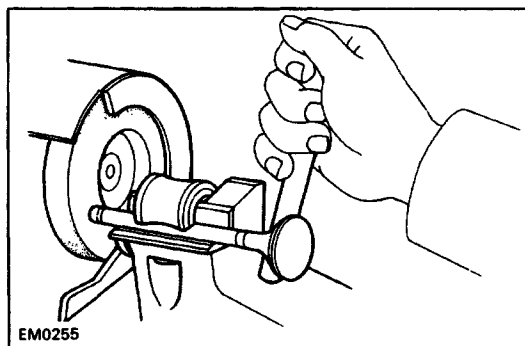

- (e) Check the surface of the valve stem tip for wear.

If the valve stem tip is worn, resurface the tip with a grinder or replace the valve.

**NOTICE: Do not grind off more than minimum.**

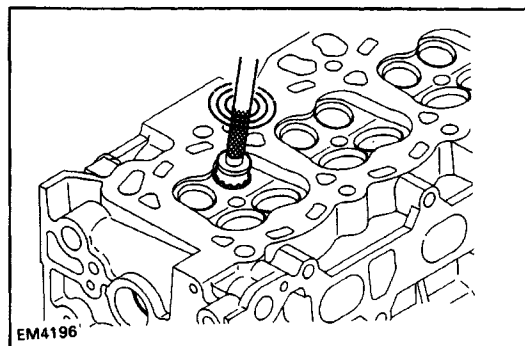

## 8. INSPECT AND CLEAN VALVE SEATS

- (a) Using a 45° carbide cutter, resurface the valve seats.  
Remove only enough metal to clean the seats.



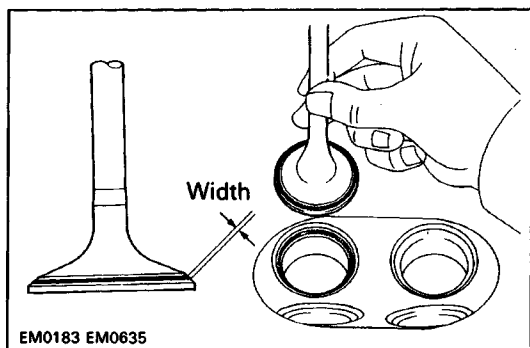

(b) Check the valve seating position.

Apply a light coat of prussian blue (or white lead) to the valve face. Lightly press the valve against the seat. Do not rotate the valve.

(c) Check the valve face and seat for the following:

- If blue appears 360° around the face, the valve is concentric. If not, replace the valve.
- If blue appears 360° around the valve seat, the guide and face are concentric. If not, resurface the seat.
- Check that the seat contact is in the middle of the valve face with the following width:

**1.2 – 11.6 mm (6.047 – 0.063 in.)**

If not, correct the valve seats as follows:

- (1) If the seating is too high on the valve face, use 30° and 45° cutters to correct the seat.

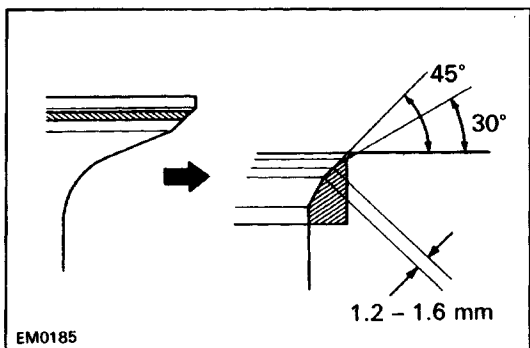

- (2) If the seating is too low on the valve face, use 60° and 45° cutters to correct the seat.

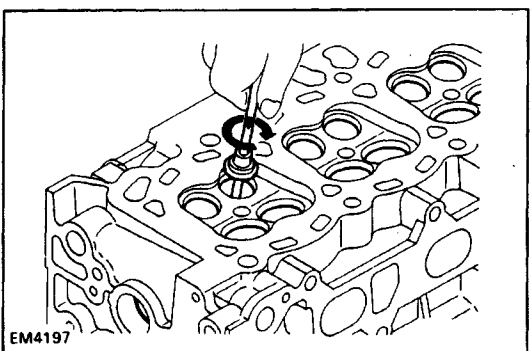
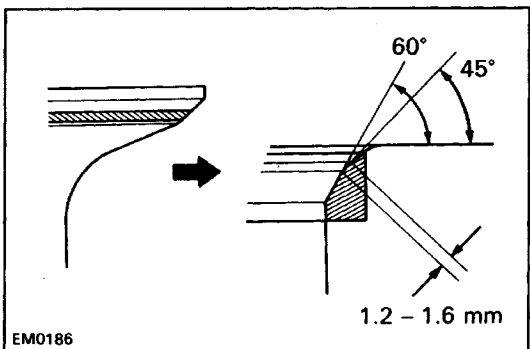

(d) Hand-lap the valve and valve seat with an abrasive compound.

(e) After hand-lapping, clean the valve and valve seat.

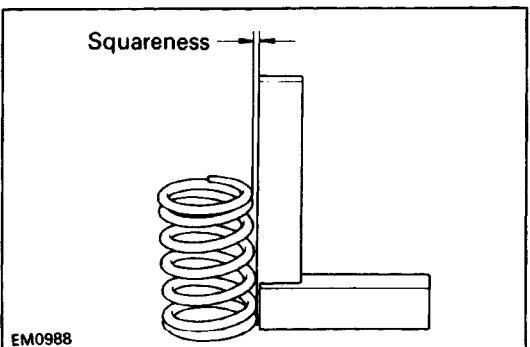

## 9. INSPECT VALVE SPRINGS

(a) Using a steel square, measure the squareness of the valve spring.

**Maximum squareness: 2.0 mm (0.079 in.)**

If squareness is greater than maximum, replace the valve spring.

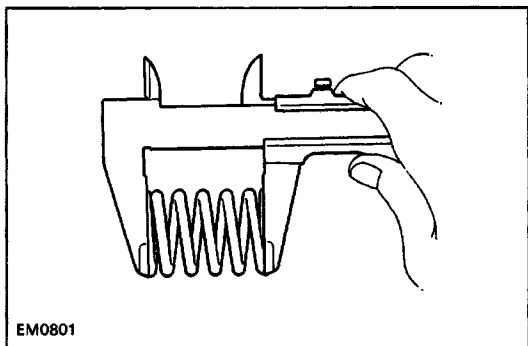

EM0801

(b) Using a vernier caliper, measure the free length of the valve spring.

**Free length: 43.8 mm (1.724 in.)**

If the free length is not as specified, replace the valve spring.

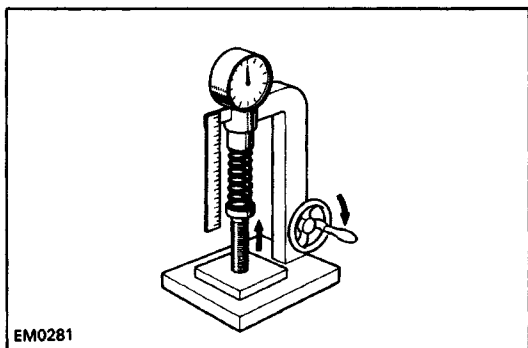

EM0281

(c) Using a spring tester, measure the tension of the valve spring at the specified installed length.

**Installed tension:**

**143 – 155 N (14.6 – 15.8 kgf, 32.2 – 34.8 lbf)  
at 34.7 mm (1.366 in.)**

If the installed tension is not as specified, replace the valve spring.

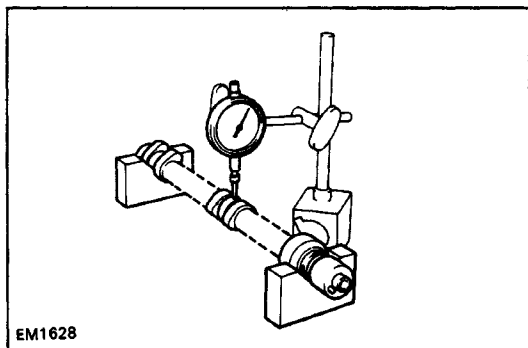

EM1628

## 10. INSPECT CAMSHAFTS AND BEARINGS

### A. Inspect camshaft for runout

(a) Place the camshaft on V-blocks.

(b) Using a dial indicator, measure the circle runout at the center journal.

**Maximum circle runout: 0.04 mm (0.0016 in.)**

If the circle runout is greater than maximum, replace the camshaft.

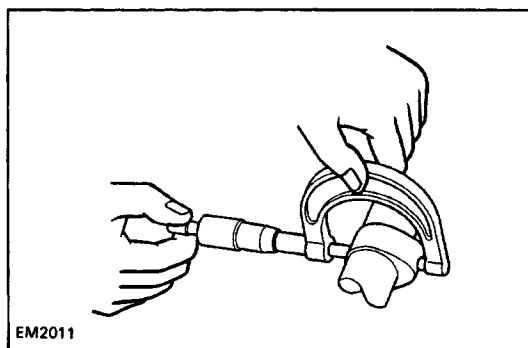

EM2011

### B. Inspect cam lobes

Using a micrometer, measure the cam lobe height.

**Standard cam lobe height:**

**Intake 35.210 – 35.310 mm  
(1.3862 – 1.3902 in.)**

**Exhaust 34.910 – 35.010 mm  
(1.3744 – 1.3783 in.)**

**Minimum cam lobe height:**

**Intake 34.81 mm (1.3705 in.)**

**Exhaust 34.51 mm (1.3587 in.)**

If the cam lobe height is less than minimum, replace the camshaft.

### C. Inspect camshaft journals

Using a micrometer, measure the journal diameter.

**Journal diameter:**

**Exhaust No.1 24.949 – 24.965 mm  
(0.9822 – 0.9829 in.)**

**Others 22.949 – 22.965 mm  
(0.9035 – 0.9041 in.)**

If the journal diameter is not as specified, check the oil clearance.

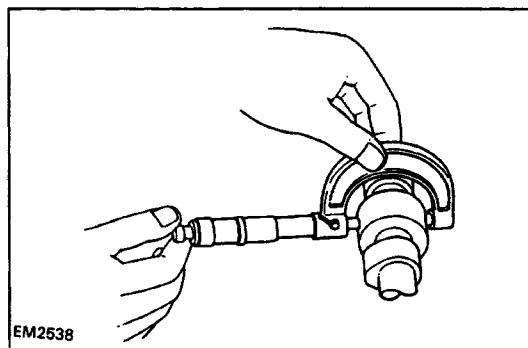

EM2538

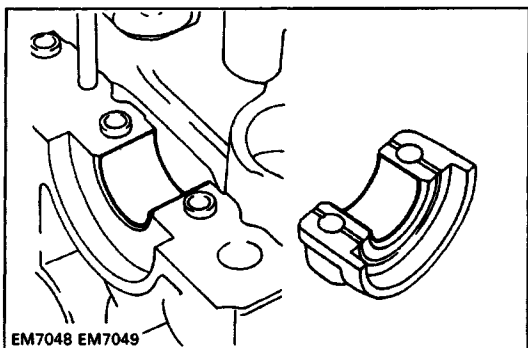

#### D. Inspect camshaft bearings

Check the bearings for flaking and scoring.  
If the bearings are damaged, replace the bearing caps and cylinder head as a set.

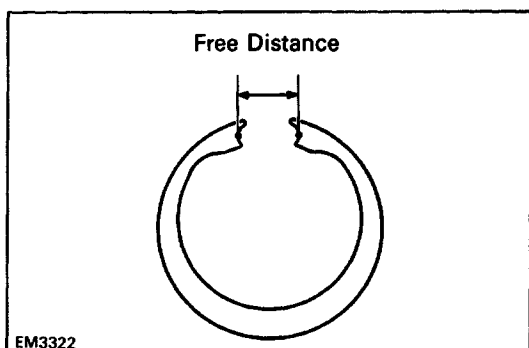

#### E. Inspect camshaft gear spring

Using a vernier caliper, measure the free distance between the spring ends.

**Free distance: 17.0 –17.6 mm (0.669 – 0.693 in.)**

If the free distance is not as specified, replace the gear spring.

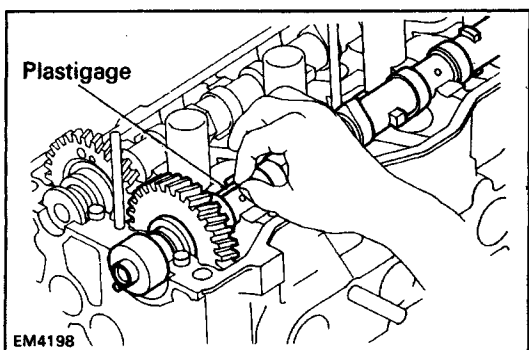

#### F. Inspect camshaft journal oil clearance

- (a) Clean the bearing caps and camshaft journals.
- (b) Place the camshafts on the cylinder head.
- (c) Lay a strip of Plastigage across each of the camshaft journals.

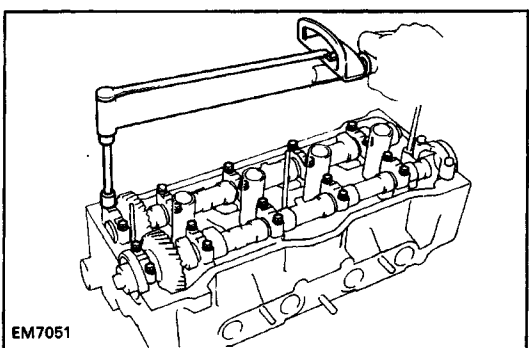

- (d) Install the bearing caps.

(See step 3 on pages [EM-105](#) to 107)

**Torque: 13 N-m (130 kgf-cm, 9 ft-lbf)**

**NOTICE: Do not turn the camshaft.**

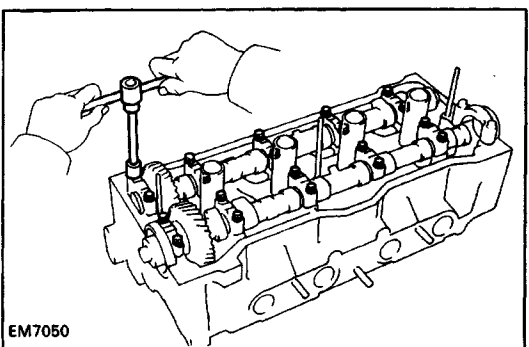

- (e) Remove the bearing caps.

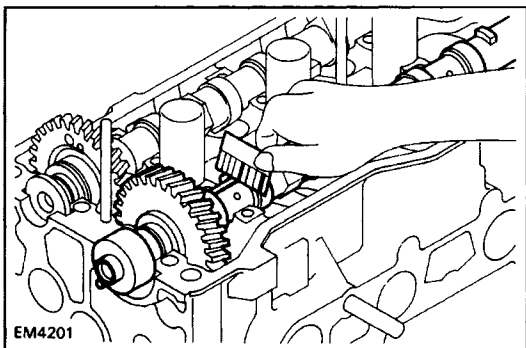

(f) Measure the Plastigage at its widest point.

**Standard oil clearance: 0.035 – 0.072 mm**  
(0.0014 – 0.0028 in.)

**Maximum oil clearance: 0.10 mm (0.0039 in.)**

If the oil clearance is greater than maximum, replace the camshaft. If necessary, replace the bearing caps and cylinder head as a set.

(g) Completely remove the Plastigage.

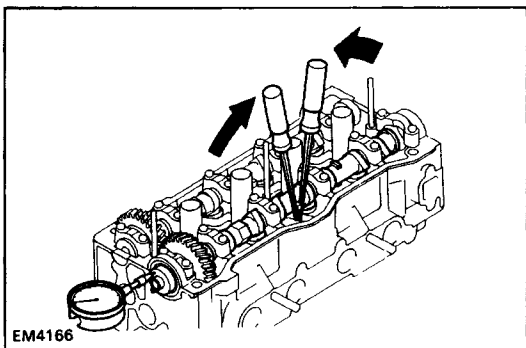

### G. Inspect camshaft thrust clearance

(a) Install the camshafts.

(See step 3 on pages [EM-105](#) to 107)

(b) Using a dial indicator, measure the thrust clearance while moving the camshaft back and forth.

**Standard thrust clearance:**

<b>Intake</b>	<b>0.030 – 0.085 mm</b> (0.0012 – 0.0033 in.)
---------------	--

<b>Exhaust</b>	<b>0.035 – 0.090 mm</b> (0.0014 – 0.0035 in.)
----------------	--

**Maximum thrust clearance: 0.11 mm (0.0043 in.)**

If the thrust clearance is greater than maximum, replace the camshaft. If necessary, replace the bearing caps and cylinder head as a set.

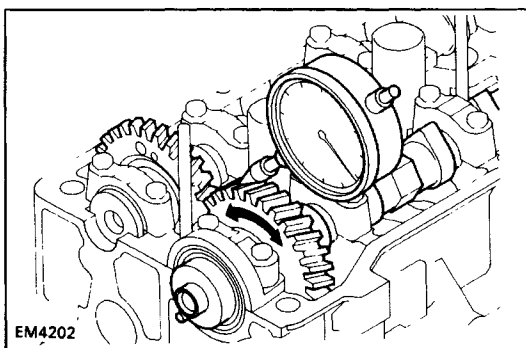

### H. Inspect camshaft gear backlash

(a) Install the camshafts without installing the exhaust camshaft sub-gear.

(See step 3 on pages [EM-105](#) to 107)

(b) Using a dial indicator, measure the backlash.

**Standard backlash: 0.020 – 0.200 mm**  
(0.0008 – 0.0079 in.)

**Maximum backlash: 0.30 mm (0.0188 in.)**

If the backlash is greater than maximum, replace the camshafts.

### 11. INSPECT VALVE LIFTERS AND LIFTER BORES

(a) Using a caliper gauge, measure the lifter bore diameter of the cylinder head.

**Lifter bore diameter: 28.005 – 28.026 mm**  
(1.1026 – 1.1034 in.)

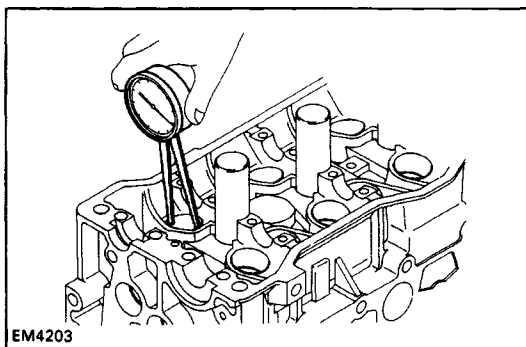

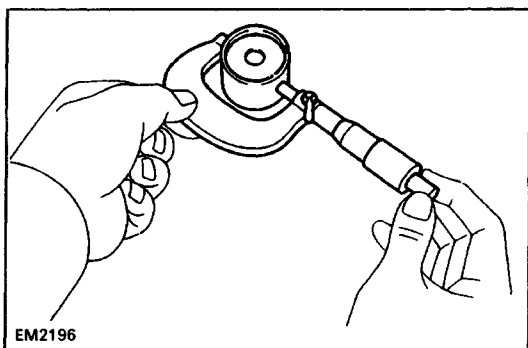

(b) Using a micrometer, measure the lifter diameter.

**Lifter diameter: 27.975 – 27.985 mm**

**(1.1014 – 1.1018 in.)**

(c) Subtract the lifter diameter measurement from the lifter bore diameter measurement.

**Standard oil clearance: 0.020 – 0.051 mm**

**(0.0008 – 0.0020 in.)**

**Maximum oil clearance: 0.07 mm (0.0028 in.)**

If the oil clearance is greater than maximum, replace the

lifter. If necessary, replace the cylinder head.

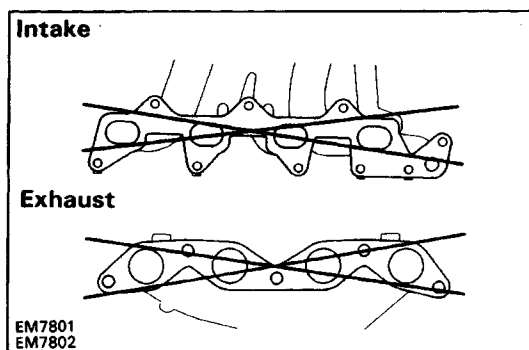

## 12. INSPECT INTAKE AND EXHAUST MANIFOLDS

Using precision straight edge and feeler gauge, measure the surface contacting the cylinder head for warpage.

**Maximum warpage:**

**Intake 0.20 mm (0.0079 in.)**

**Exhaust 0.30 mm (0.0118 in.)**

If warpage is greater than maximum, replace the manifold.

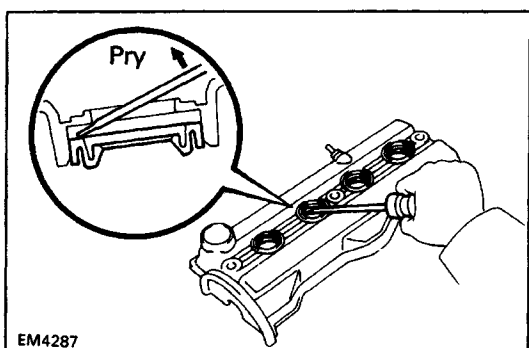

## 13. IF NECESSARY, REPLACE SPARK PLUG TUBE GASKET

(a) Using a screwdriver, pry out the gasket.

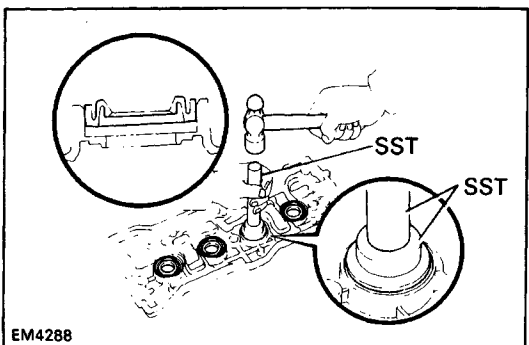

(b) Using SST, tap in a new gasket until its surface is flush with the upper edge of the cylinder head cover.

SST 09550-10012 (09552-10010, 09560-10010)

(c) Apply a light coat of IMP grease to the gasket lip.

## ASSEMBLY OF CYLINDER HEAD

(See page EM-81)

HINT:

- Thoroughly clean all parts to be assembled.
- Before installing the parts, apply new engine oil to all sliding and rotating surfaces.
- Replace all gaskets and oil seals with new ones.

### 1. INSTALL SPARK PLUG TUBES

HINT: When using a new cylinder head, spark plug tubes must be installed.

(a) Apply adhesive to the spark plug tube hole of the cylinder head.

**Adhesive: Part No. 08833-00070, THREE BOND 1324 or equivalent**

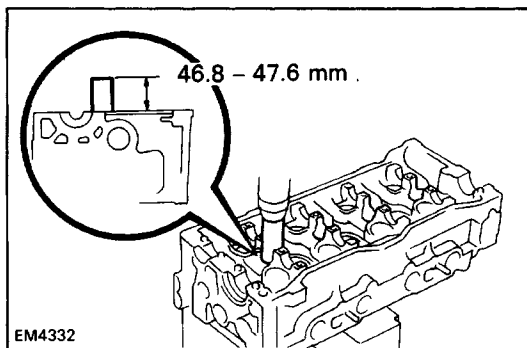
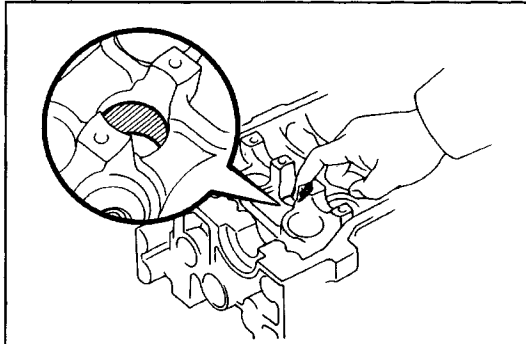

(b) Using a press, press in a new spark plug tube until there is 46.8 - 47.6 mm (1.843 - 1.874 in.) protruding from the cylinder head.

**NOTICE: Avoid tapping a new spark plug tube in too far by measuring the amount of protrusion while pressing.**

### 2. INSTALL VALVES

(a) Using SST, push in a new oil seal.  
SST 09201-41020

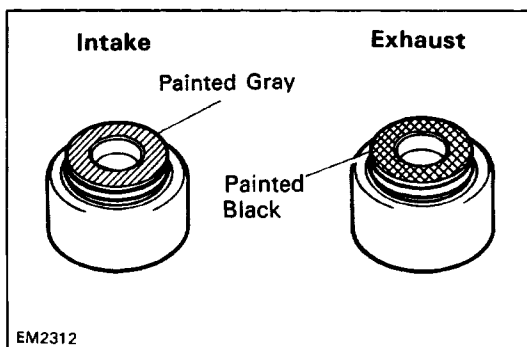
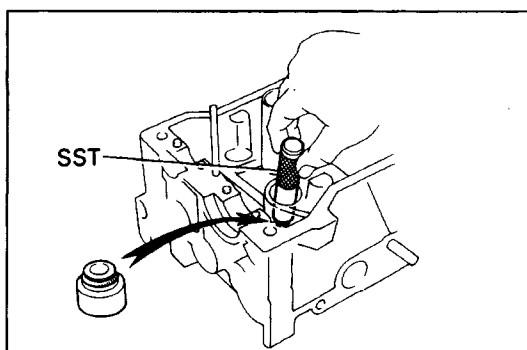

HINT: The intake valve oil seal is brown and the exhaust valve oil seal is black.

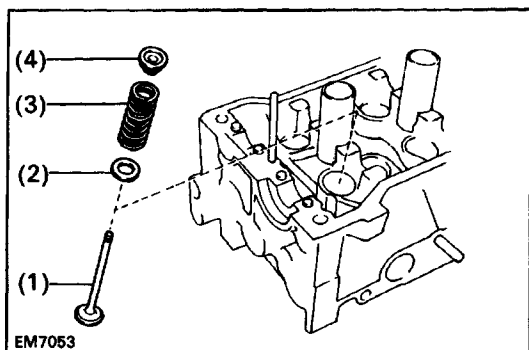

(b) Install the following parts:

- (1) Valve
- (2) Spring seat
- (3) Valve spring
- (4) Spring retainers

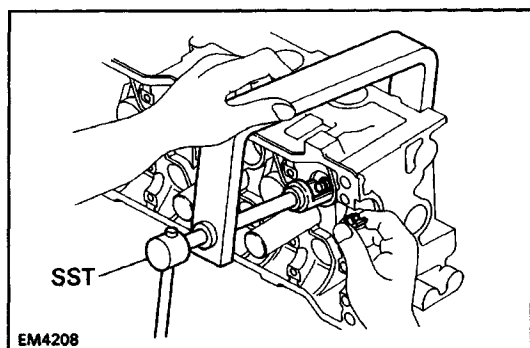

(c) Using SST, compress the valve spring and place the two keepers around the valve stem.

SST 09202-70010

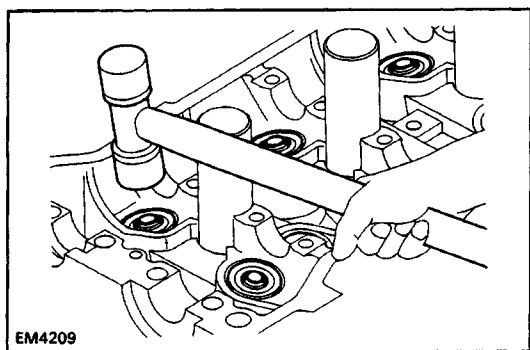

(d) Using a plastic-faced hammer, lightly tap the valve stem tip to assure proper fit.

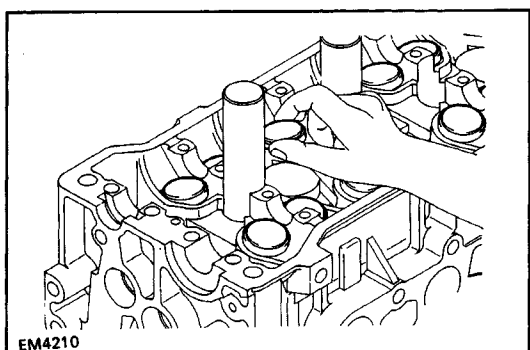

### 3. INSTALL VALVE LIFTERS AND SHIMS

- (a) Install the valve lifter and shim.
- (b) Check that the valve lifter rotates smoothly by hand.

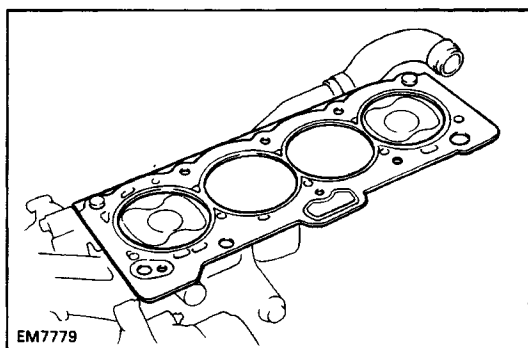

## INSTALLATION OF CYLINDER HEAD

(See page EM-81)

### 1. INSTALL CYLINDER HEAD

- (a) Place a new cylinder head gasket in position on the cylinder block.

**NOTICE: Be careful of the installation direction.**

- (b) Place the cylinder head in position on the cylinder head gasket.

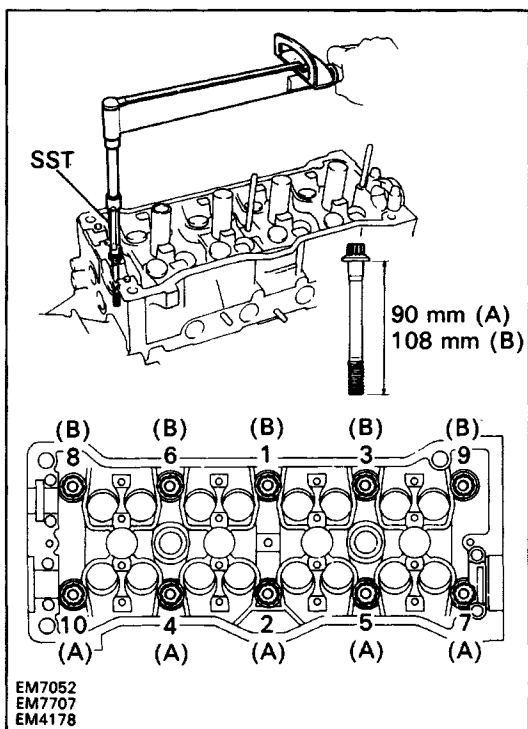

- (c) Apply a light coat of engine oil on the threads and under the heads of the cylinder head bolts.
- (d) Install the plate washer to each cylinder head bolt.
- (e) Using SST, install and uniformly tighten the ten cylinder head bolts in several passes in the sequence shown.

SST 09205-16010

**Torque: 60 N-m (610 kgf-cm, 44 ft-lbf)**

HINT: Cylinder head bolts are in length of 90 mm (3.54 in.) and 108 mm (4.25 in.). Install the 90 mm (3.54 in.) bolts (A) in intake manifold side positions. Install the 108 mm (4.25 in.) bolts (B) in exhaust manifold side positions.

### 2. ASSEMBLE EXHAUST CAMSHAFT

- (a) Mount the hexagon wrench head portion of the camshaft in a vise.

**NOTICE: Be careful not to damage the camshaft.**

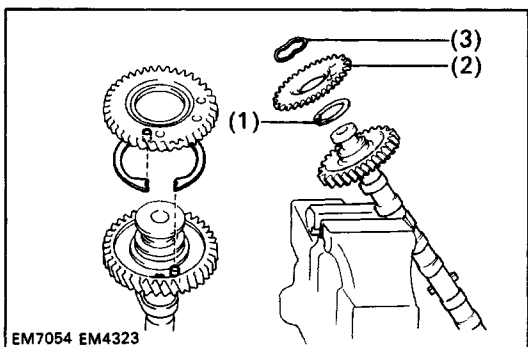
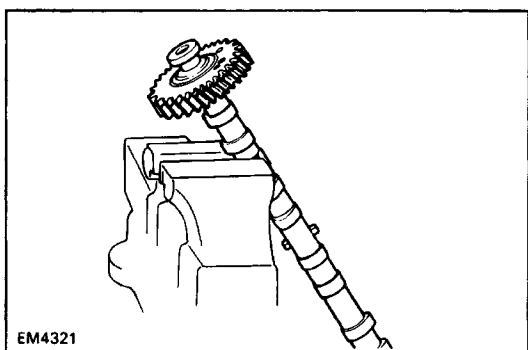

- (b) Install the following parts:

- (1) Camshaft gear spring
- (2) Camshaft sub-gear
- (3) Wave washer

HINT: Align the pins on the gears with the gear spring ends.



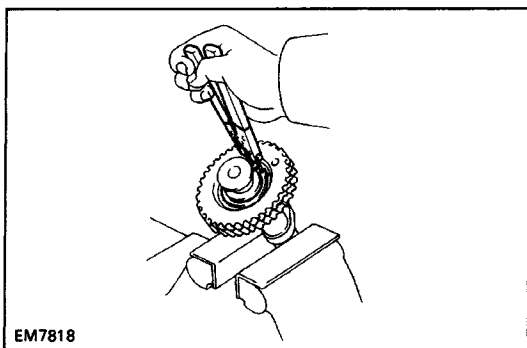

(c) Using snap ring pliers, install the snap ring.

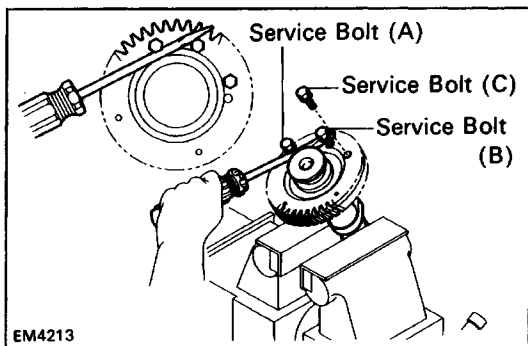

(d) Insert service bolts (A) and (13) into the service hole of the camshaft sub-gear.

(e) Using a screwdriver, align the holes of the camshaft drive gear and sub-gear by turning camshaft sub-gear clockwise, and install a service bolt (C).

**NOTICE: Be careful not to damage the camshaft.**

### 3. INSTALL CAMSHAFTS

**NOTICE: Since the thrust clearance of the camshaft is small, the camshaft must be kept level while it is being installed. If the camshaft is not kept level, the portion of the cylinder head receiving the shaft thrust may crack or be damaged, causing the camshaft to seize or break. To avoid this, the following steps should be carried out.**

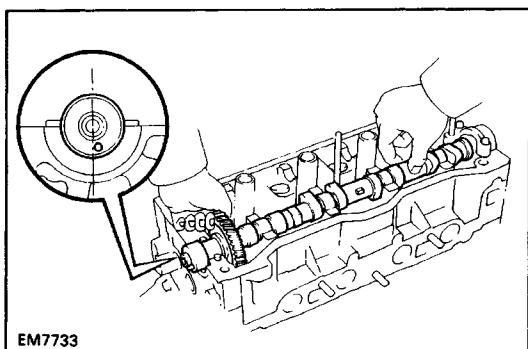

#### A. Install exhaust camshaft

(a) Apply MP grease to the thrust portion of the camshaft.

(b) Place the intake camshaft so the knock pin is located slightly counterclockwise from the vertical axis of the camshaft.

**HINT: The above angle allows the No.1 and No.3 cylinder cam lobes of the exhaust camshaft to push their valve lifters evenly.**

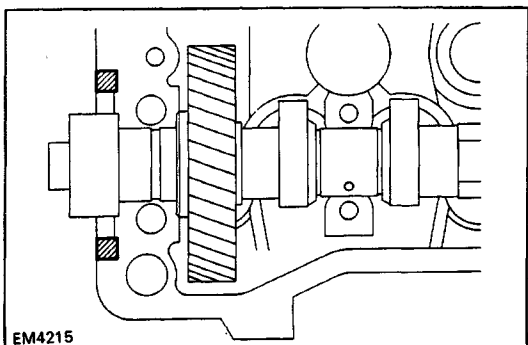

(c) Remove any old packing (FIPG) material.

(d) Apply seal packing to the cylinder head as shown in the illustration.

**Seal packing: Part No. 08826-00080 or equivalent**

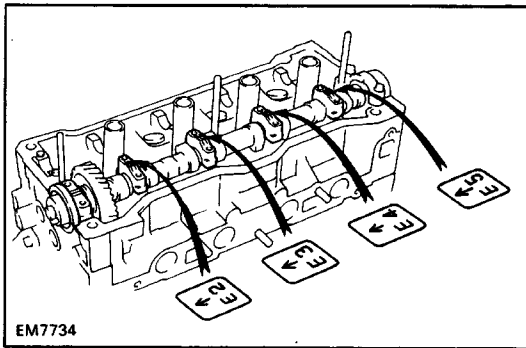

- (e) Install the five bearing caps in their proper locations.

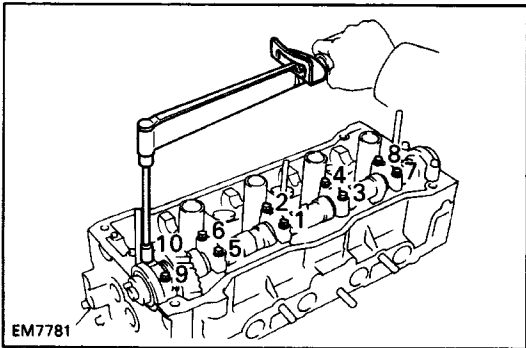

- (f) Apply a light coat of engine oil on the threads and under the heads of the bearing cap bolts.  
 (g) Install and uniformly tighten the ten bearing cap bolts in several passes in the sequence shown.  
**Torque: 13 N-m (130 kgf-cm, 9 ft-lbf)**

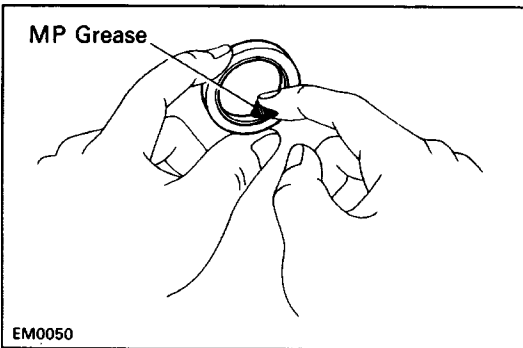

- (h) Apply MP grease to a new oil seal lip.

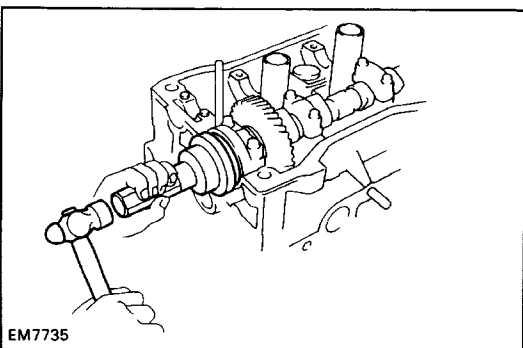

- (i) Using SST, tap in the oil seal.  
 SST 09223-46011

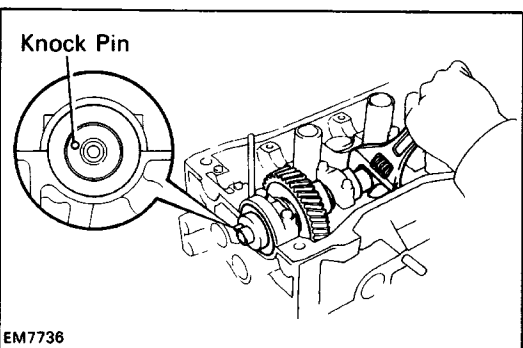

## B. Install intake camshaft

- (a) Set the intake camshaft so the knock pin is slightly above the top of the cylinder head.

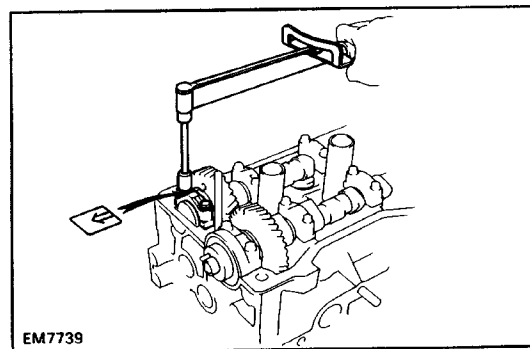
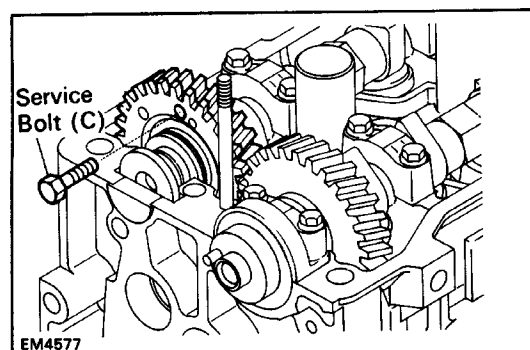
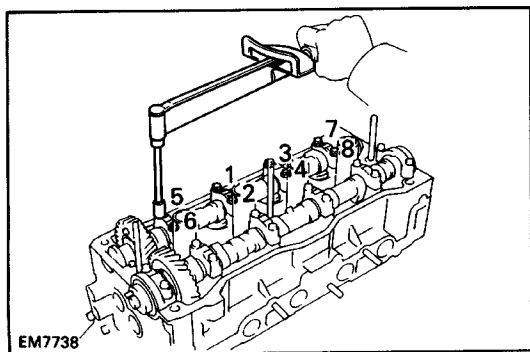
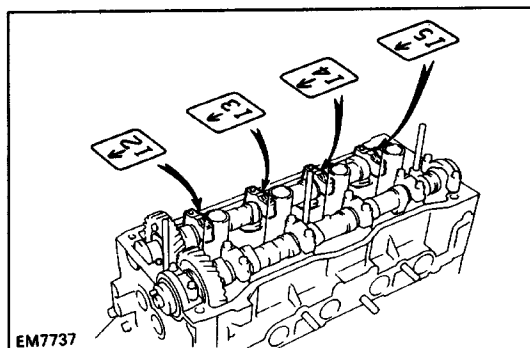
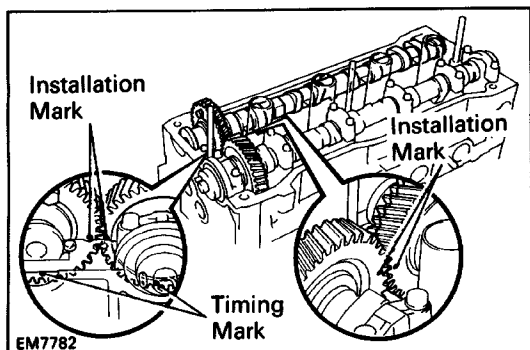

- (b) Apply MP grease to the thrust portion of the camshaft.
- (c) Engage the intake camshaft gear to the exhaust camshaft gear by matching the assembly installation marks on each gear.

**NOTICE:** There are also timing marks (for TDC) on each gear as shown in the illustration. Do not use these marks.

- (d) Roll down the intake camshaft onto the bearing journals while engaging gears with each other.  
HINT: The above angle allows the No.1 and No.3 cylinder cam lobes of the intake camshaft to push their valve lifters evenly.
- (e) Install the four bearing caps in their proper locations.

- (f) Apply a light coat of engine oil on the threads and under the heads of the bearing cap bolts.
- (g) Install and uniformly tighten the eight bearing cap bolts in several passes in the sequence shown.

**Torque: 13 N-m (130 kgf-cm, 9 ft-lbf)**

- (h) Remove the service bolt (C).

- (i) Install the No.1 bearing cap with the arrow mark facing forward.

**NOTICE:** If the No.1 bearing cap does not fit properly, push the camshaft gear backwards by prying apart the cylinder head and camshaft gear with a screwdriver.

- (j) Apply a light coat of engine oil on the threads and under the heads of the bearing cap bolts.
- (k) Install and alternately tighten the two bolts in several passes.

**Torque: 13 N-m (130 kgf-cm, 9 ft-lbf)**

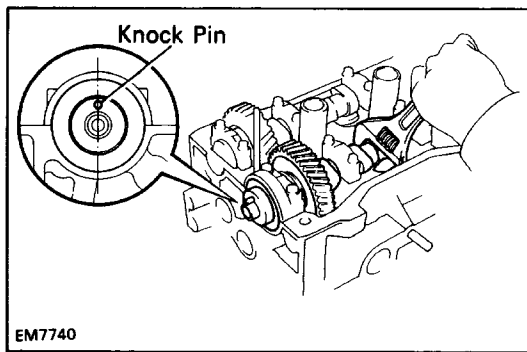

- (l) Turn the exhaust camshaft clockwise, and set it with knock pin facing upward.

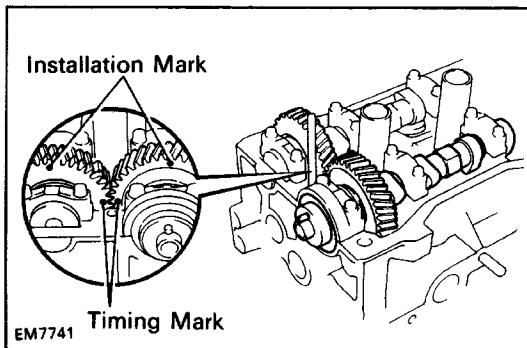

- (m) Check that the timing marks of the camshaft gears are aligned.

HINT: The assembly installation marks are on upside.

#### 4. CHECK AND ADJUST VALVE CLEARANCE

(See page [EM-13](#))

Turn the camshaft and position the cam lobe upward, and check and adjust the valve clearance.

**Valve clearance (Cold):**

**Intake 0.15 – 0.25 mm (0.006 – 0.010 in.)**

**Exhaust 0.20 – 0.30 mm (0.008 – 0.012 in.)**

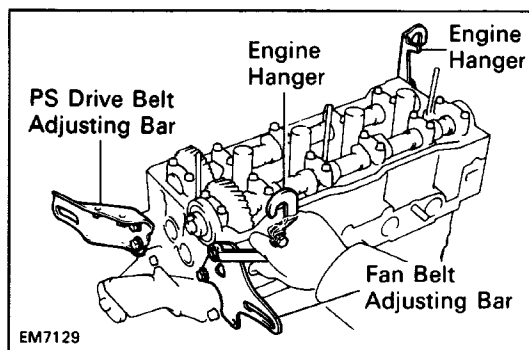

#### 5. INSTALL PS DRIVE BELT ADJUSTING STRUT

Install the adjusting strut with the two bolts.

**Torque: 39 N-m (400 kgf-cm, 29 ft-lbf)**

#### 6. INSTALL ENGINE HANGERS

Install the engine hanger with the bolt. Install the two engine hangers.

**Torque: 27 N-m (280 kgf-cm, 20 ft-lbf)**

#### 7. INSTALL FAN BELT ADJUSTING BAR

Install the adjusting bar with the two bolts.

**Torque: 20 N-m (200 kgf-cm, 14 ft-lbf)**

#### 8. INSTALL CAMSHAFT TIMING PULLEY

(See step 7 on page [EM-41](#))

#### 9. INSTALL TIMING BELT

(See steps 8 to 13, 15 to 17, 19 to 22 on pages [EM-41](#) to 45)

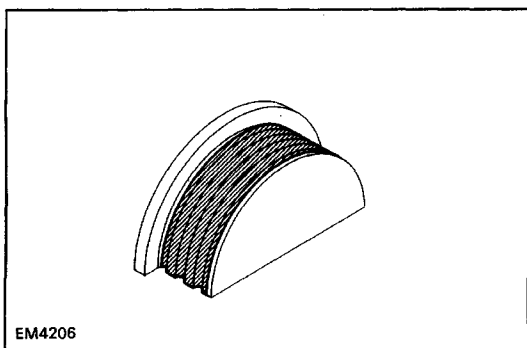

EM4206

## 10. INSTALL SEMI-CIRCULAR PLUG

- (a) Remove any old packing (FIPG) material.
- (b) Apply seal packing to the circular plug.

**Seal packing: Part No. 08826-00080 or equivalent**

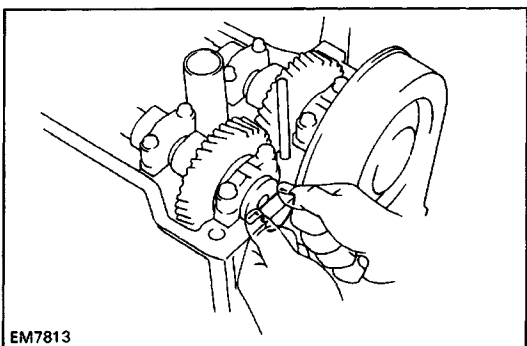

EM7813

- (c) Install the semi-circular plug to the cylinder head.

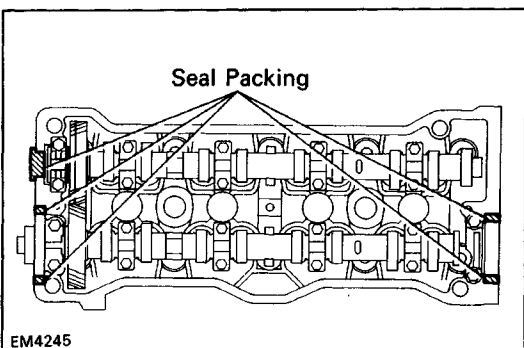

EM4245

## 11. INSTALL CYLINDER HEAD COVER

- (a) Remove any old packing (FIPG) material.
- (b) Apply seal packing to the cylinder head as shown in the illustration.

**Seal packing: Part No. 08826-00080 or equivalent**

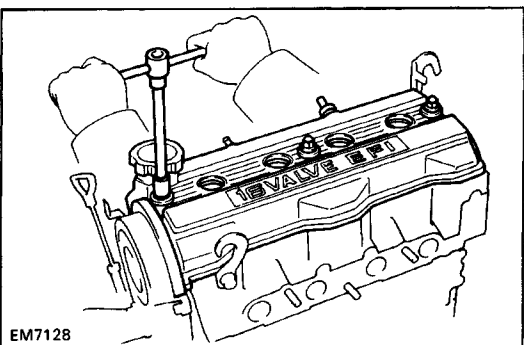

EM7128

- (c) Install the gasket to the head cover.
- (d) Install the head cover with the three grommets and cap nuts. Uniformly tighten the nuts in several passes.

**Torque: 7.8 N-m (80 kgf-cm, 69 in.-lbf)**

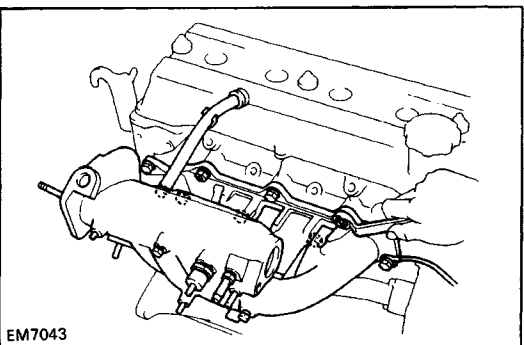

EM7043

## 12. INSTALL INTAKE MANIFOLD

- (a) Install a new gasket and the intake manifold with the seven bolts and two nuts. Uniformly tighten the bolts and nuts in several passes.

**Torque: 19 N-m (195 kgf-cm, 14 ft-lbf)**

- (b) Connect the PCV hose to PCV valve on the cylinder head.

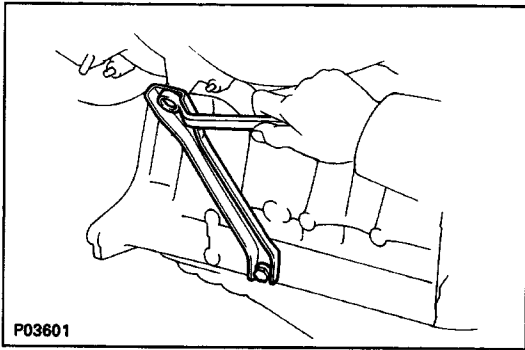

(c) Install the manifold stay with the two bolts. Alternately tighten the bolts.

**Torque:**

**12 mm bolt head 19 N-m (195 kgf-cm, 14 ft-lbf)**

**14 mm bolt head 39 N-m (400 kgf-cm, 29 ft-lbf)**

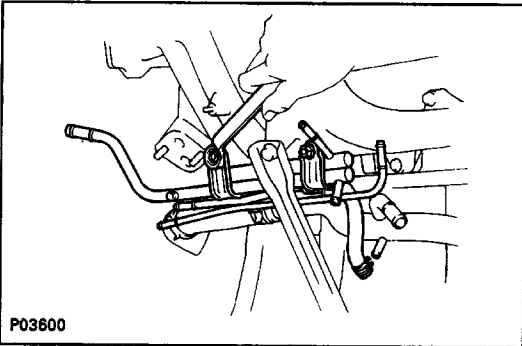

**13. INSTALL AIR PIPE**

(a) Install the air pipe with the two nuts.

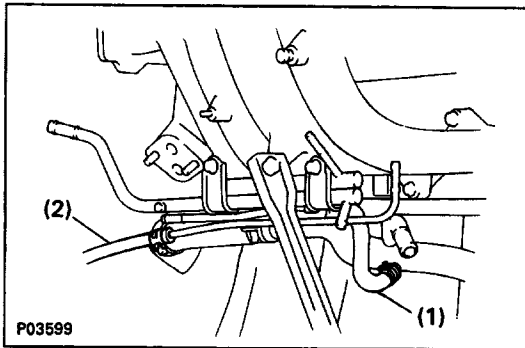

(b) Connect the following hoses:

(1) Water inlet pipe water by-pass hose

(2) Fuel return hose (from fuel filter)

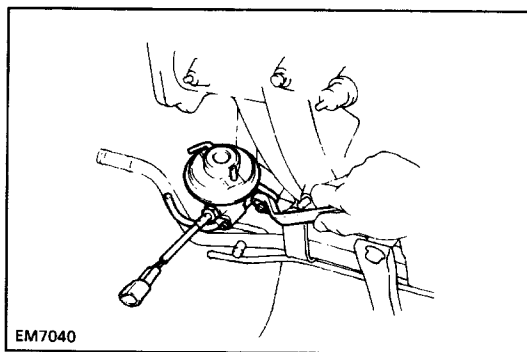

**14. INSTALL EGR VALVE**

Install the EGR valve with the two nuts.

**Torque: 13 N-m (130 kgf-cm, 9 ft-lbf)**

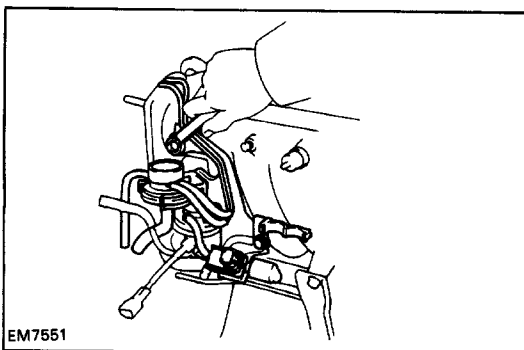

**15. INSTALL VACUUM PIPE, EGR VACUUM MODULATOR AND EGR VSV**

(a) Install the vacuum pipe, vacuum modulator and VSV assembly with the two nuts.

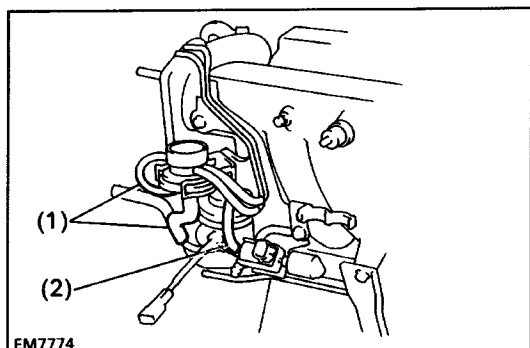

- (b) Connect the following hoses:
- (1) Two vacuum hoses (from EGR vacuum modulator) to EGR valve
  - (2) Vacuum hose (from EGR VSV) to EGR valve

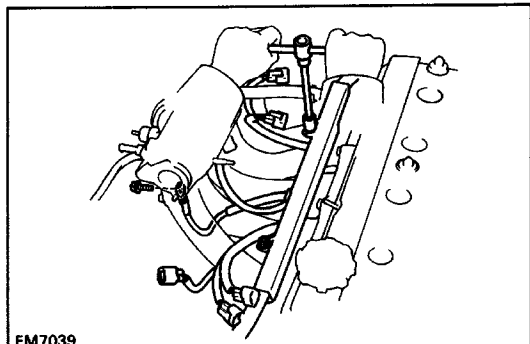

#### 16. INSTALL ENGINE WIRE TO INTAKE MANIFOLD

- (a) Install the engine wire with the three bolts.
- (b) Install the engine wire on the engine to vacuum pipe with the wire clamp.
- (c) Connect the following connectors:
  - EGR VSV connector
  - (CALIF. only)  
EGR gas temperature sensor connector
  - Vacuum sensor connector

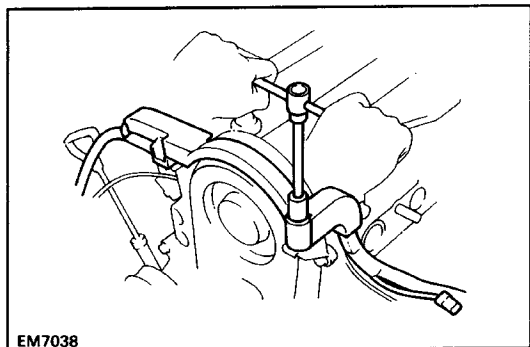

#### 17. INSTALL ENGINE WIRE TO No.3 TIMING BELT COVER

- (a) Install the wire clamp on the engine wire to the wire bracket.
- (b) Install the engine wire with the bolt.
- (c) Connect the following connectors and wire:
  - Alternator connector.
  - Alternator wire
  - Oil pressure switch connector
  - A/C compressor connector

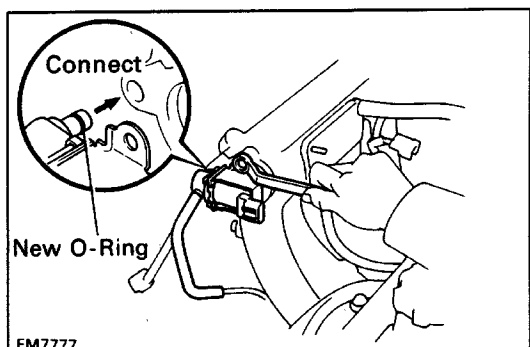

#### 18. INSTALL ACV

- (a) Install a new O-ring to the ACV.
  - (b) Apply soapy water to the O-ring.
  - (c) Install the ACV with the bolt and nut.
  - (d) Connect the air hose to the air pipe.
- Torque: 13 N-m (130 kgf-cm, 9 ft-lbf)**

#### 19. INSTALL INJECTORS AND DELIVERY PIPE

(See steps 1 to 5 on pages [FI-158](#) and [159](#))

#### 20. INSTALL THROTTLE BODY

(See steps 2 to 5 on page [FI-191](#))

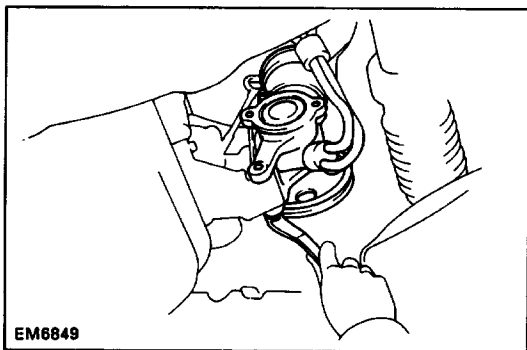

## 21. INSTALL PS PUMP

- (a) Install the PS pump and drive belt with the two bolts.

**Torque: 39 N-m (400 kgf-cm, 29 ft-lbf)**

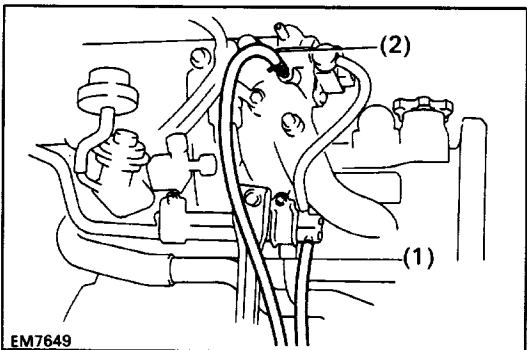

- (b) Connect the following hoses:
- (1) Air hose to air pipe
  - (2) Air hose to intake manifold

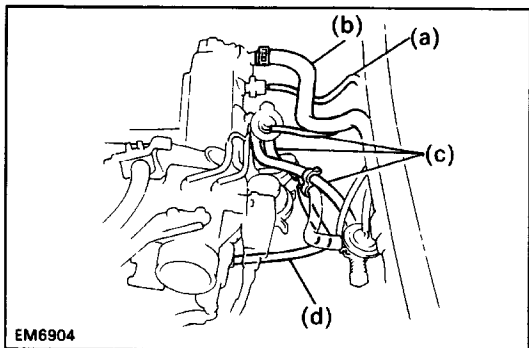

## 22. CONNECT VACUUM HOSES

- (a) Vacuum sensor hose to gas filter on intake manifold
- (b) Brake booster vacuum hose to intake manifold
- (c) Three A/C vacuum hoses to ASV on intake manifold
- (d) A/C vacuum hose to air pipe

## 23. INSTALL WATER INLET AND INLET HOUSING

- (a) Remove any old packing (FIPG) material and be careful not to drop any oil on the contact surfaces of the inlet housing and cylinder head.

- Using a razor blade and gasket scraper, remove all the oil packing (FIPG) material from the gasket surfaces and sealing groove.
- Thoroughly clean all components to remove all the loose material.
- Using a non-residue, clean both sealing surfaces.

- (b) Apply seal packing to the inlet housing groove.

**Seal packing: Part No. 08826-00100 or equivalent**

- Install a nozzle that has been cut to a 2 – 3 mm (0.08 – 0.12 in.) opening.

**HINT:** Avoid applying an excessive amount to the surface.

- Parts must be assembled within 15 minutes of application. Otherwise the material must be removed and reapplied.
- Immediately remove nozzle from the tube and reinstall cap.

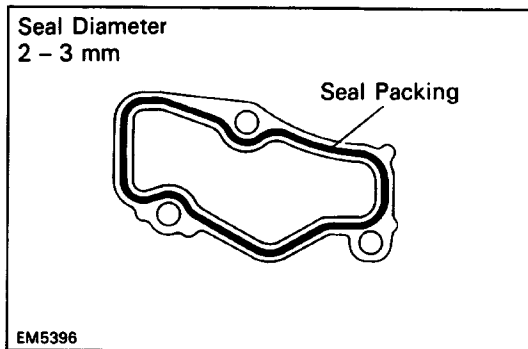



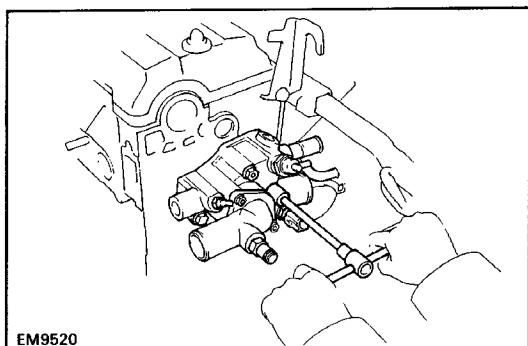

- (c) Install the water inlet and inlet housing assembly with the bolt and two nuts.

**Torque: 20 N-m (200 kgf-cm, 14 ft-lbf)**

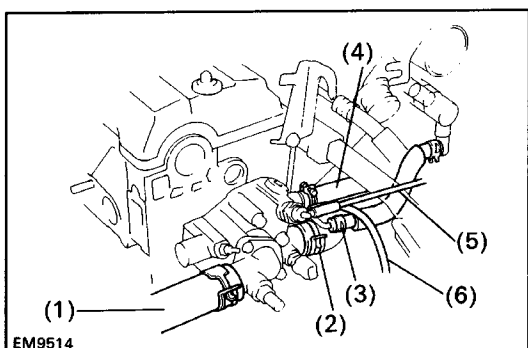

- (d) Connect the following hoses: ,
- (1) Lower radiator hose
  - (2) Water inlet pipe hose
  - (3) Auxiliary air valve water by-pass hose
  - (4) Heater water hose
  - (5) EVAP BVSV vacuum hose (from port P of throttle body)
  - (6) EVAP BVSV vacuum hose (from charcoal canister)
- (e) Connect the following connectors:
- Water temperature sender gauge connector
  - Water temperature sensor connector

#### 24. INSTALL WATER OUTLET

- (a) Remove any old packing (FIPG) material and be careful not to drop any oil on the contact surfaces of the water outlet and cylinder head.

- Using a razor blade and gasket scraper, remove all the oil packing (FIPG) material from the gasket surfaces and sealing groove.
- Thoroughly clean all components to remove all the loose material.
- Using a non-residue, clean both sealing surfaces.

- (b) Apply seal packing to the water outlet groove.

**Seal packing: Part No. 08826-00100 or equivalent**

- Install a nozzle that has been cut to a 2 – 3 mm (0.08 – 0.12 in.) opening.

**HINT:** Avoid applying an excessive amount to the surface.

- Parts must be assembled within 15 minutes of application. Otherwise the material must be removed and reapplied.
- Immediately remove nozzle from the tube and reinstall cap.

- (c) Install the water outlet with the two bolts.

**Torque: 15 N-m (150 kgf-cm, 11 ft-lbf)**

- (d) Connect the upper radiator hose to the water outlet.

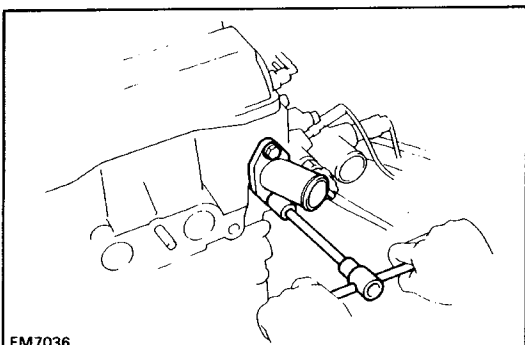
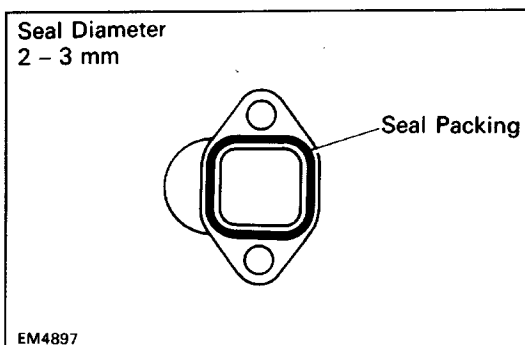

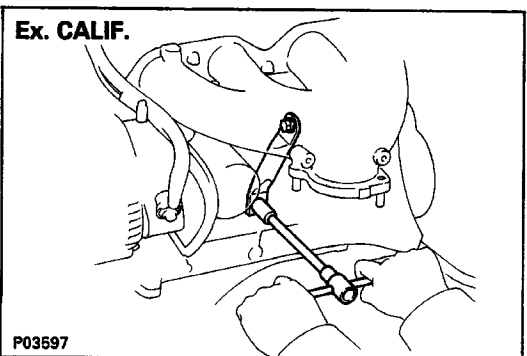
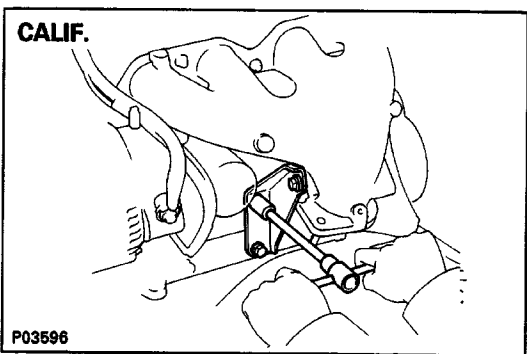
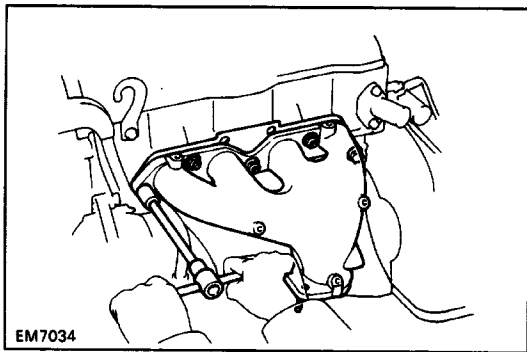
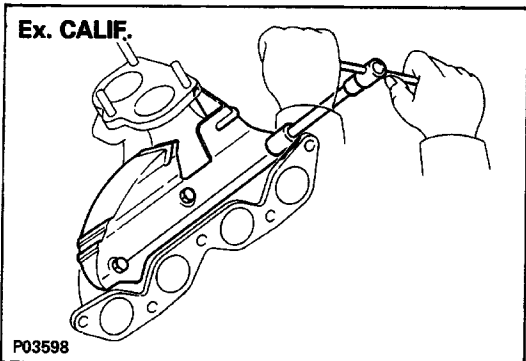
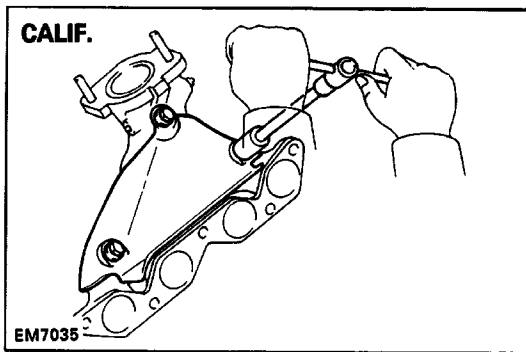

## 25. INSTALL EXHAUST MANIFOLD

- (a) Install the lower heat insulator to the exhaust manifold with the three bolts.

- (b) Install a new gasket and the exhaust manifold with the two bolts and three new nuts. Uniformly tighten the bolts and nuts in several passes.

**Torque: 25 N·m (250 kgf·cm, 18 ft·lbf)**

- (c) Install the manifold stay with the three (CALIF.) or two (Ex. CALIF.) bolts. Alternately tighten the bolts.

**Torque: 39 N·m (400 kgf·cm, 29 ft·lbf)**

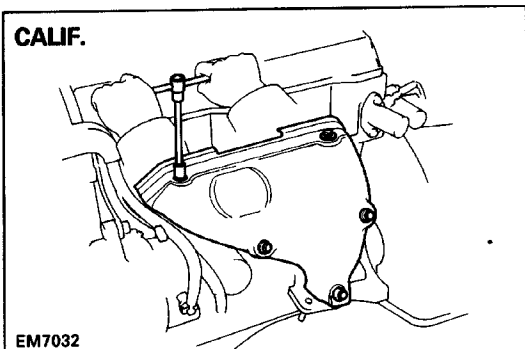

- (d) Install the upper heat insulator with the five (CALIF.) or four (Ex. CALIF.) bolts.

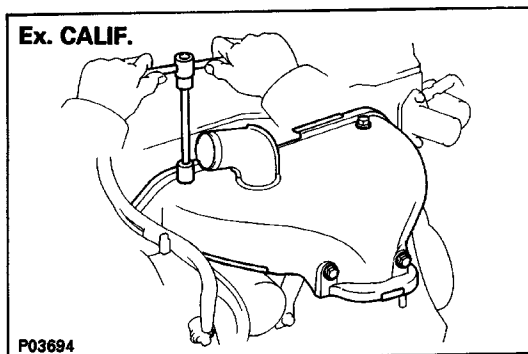

26. INSTALL DISTRIBUTOR (See page [IG-24](#))
27. INSTALL FRONT EXHAUST PIPE  
(See step 17 on page [EM-217](#))
28. INSTALL SUSPENSION LOWER CROSS MEMBER  
(See page 18 on page [EM-218](#))
29. INSTALL ENGINE UNDER COVERS
30. INSTALL AIR CLEANER
31. INSTALL ACCELERATOR CABLE, AND ADJUST IT
32. ( A/T )  
CONNECT THROTTLE CABLE, AND ADJUST IT
33. FILL WITH ENGINE COOLANT (See page [CO-6](#))  
Capacity (w/ Heater):  
M/T 5.2 liters (5.5 US qts, 4.6 Imp. qts)  
A/T 5.6 liters (5.9 US qts, 4.9 Imp. qts)
34. CONNECT CABLE TO NEGATIVE TERMINAL OF BATTERY
35. START ENGINE AND CHECK FOR LEAKS
36. PERFORM ENGINE ADJUSTMENT
  - (a) Adjust the ignition timing. (See page [IG-25](#))  
Ignition timing:  
10° BTDC idle  
(w/ Terminals TE1 and E1 connected)
  - (b) Adjust the idle speed. (See page [MA-8](#))  
Idle speed: 800 rpm (w/ Cooling fan OFF)
37. PERFORM ROAD TEST  
Check for abnormal noise, shock, slippage, correct shift points and smooth operation.
38. RECHECK ENGINE COOLANT LEVEL AND OIL LEVEL